



International  
Paralympic Committee

# Powerlifting Rules & Regulations 2013-2016

December 2012





International  
**Paralympic**  
Committee

## **IPC Powerlifting**

### **Rules & Regulations 2013-2016**

Note: These Rules and Regulations are in full effect from 1 January 2013.

#### **International Paralympic Committee**

Adenauerallee 212-214 Tel. +49 228 2097-260  
53113 Bonn, Germany Fax +49 228 2097-209

[www.paralympic.org/Powerlifting](http://www.paralympic.org/Powerlifting)  
[ipcpowerlifting@paralympic.org](mailto:ipcpowerlifting@paralympic.org)

## PREAMBLE

These IPC Powerlifting Rules and Regulations are mandatory for all IPC Powerlifting recognised competitions. The overall governance and management of all IPC Sports (including IPC Powerlifting) is subject to the detailed provisions of Chapter 2.7 of the IPC Handbook.

### **Governance**

The International Paralympic Committee (IPC) acts as the International Federation for the Sport of Powerlifting. It is responsible for, amongst other things, organizing international Competitions and drawing up rules and regulations relevant to the Sport of Powerlifting, and ensuring that they are followed. IPC carries out its responsibilities as International Federation under the name “IPC Powerlifting”, and the term “IPC Powerlifting” should therefore be read in these Technical Rules and Regulations as being equivalent to IPC.

### **Printing of Rules and Regulations**

All rules of IPC Powerlifting are the copyright property of the IPC and have been published for the benefit of NPCs, athletes, officials and others who are engaged in an official capacity with IPC Powerlifting. These rules and regulations may be reprinted or translated by any organisation with a legitimate need to do so, subject to IPC’s continuing ability to assert its copyright in the rules and regulations, including the right to insist on an assignment to the IPC of the copyright in any translated version of these rules and regulations. The English version of these rules and regulations shall be accepted as the authoritative version for the purpose of interpretation.

### **Changes to these Rules and Regulations**

Please note that these rules may be changed at any time as a result, for example, of changes in classification related matters or where IPC Powerlifting otherwise considers it necessary to do so.

Changes may therefore become effective before 2016 in which case proper notice of any such changes will be given.

*Table of Contents*

PREAMBLE .....	2
1. IPC POWERLIFTING REGULATIONS.....	6
1.1 IPC Powerlifting recognized competitions .....	6
1.2 Competition Cycle.....	6
1.3 Competition Management.....	6
1.4 Paralympic Games .....	8
1.5 AH Formula .....	9
1.6 Athletes' Eligibility.....	10
1.7 Minimum Qualification Standards (MQS).....	10
2. IPC POWERLIFTING TECHNICAL OFFICIALS.....	11
2.1 Uniform and Dress Code.....	11
2.2 Technical Officials Selection, Roles and Responsibilities.....	11
2.3 The Technical Delegate.....	14
2.4 Technical Delegate duties: .....	15
2.5 The Jury.....	16
2.6 The President of the Jury.....	17
2.7 Members of the Jury .....	17
2.8 Referees .....	18
2.9 The Chief Referee .....	19
2.10 Referees Duties .....	19
2.11 Competition Secretary .....	21
2.12 The Local Organizing Committee Technical Officials.....	22
Speaker/Announcer .....	22
Time Keeper .....	23
Marshall.....	24
Technical Controllers .....	25

2.13 Spotters/Loaders.....	26
▪ Chief Spotter/Loader .....	27
▪ Side Spotter/Loaders:.....	28
3. THE COACH .....	29
4. PRE-COMPETITION PROCESSES .....	30
4.1 Entries .....	30
4.2 Technical Meeting.....	31
4.3 Technical Officials Meeting .....	32
4.4 Lot Draw .....	32
4.5 Kit Check .....	32
4.6 Weigh-In .....	33
4.7 Athletes Presentation.....	35
5. PROTEST (GENERAL CONDUCT, PROTESTS & APPEALS) .....	36
5.1 Conduct.....	36
5.2 Protests and Appeals .....	37
6. RESULTS .....	38
6.1 Individual Competitors .....	38
6.2 Teams.....	38
6.3 Tie Breaking for Team Points.....	39
7. RANKINGS.....	39
8. RECORDS .....	40
8.1 General.....	40
8.2 World Records .....	41
8.3 Regional Records.....	43
9. MEDAL AWARDS.....	43
10. PROCESS FOR APPROVED COMPETITIONS .....	44
11. RETURN TO FIELD OF PLAY DECISIONS .....	45

12. IPC POWERLIFTING TECHNICAL RULES .....	45
12.1 Events and Programme of Events .....	45
12.2 Competition Format .....	46
12.3 Age Groups .....	47
12.4 Competition Venue .....	48
12.5 Field of Play (FOP) .....	49
12.6 Sport Equipment .....	50
12.7 Scoreboard & Attempt Board .....	57
12.8 Lights.....	57
12.9 Timing System .....	58
12.10 Athletes Personal Costume and Equipment .....	58
13 COMPETITION RULES .....	66
13.1 The Round System .....	66
13.2 The Competition .....	68
13.3 The Bench Press – sequence of events .....	71
13.3.1 The “Start” Command.....	71
13.3.2 The “Lift” .....	71
13.3.3 The “Rack” Command .....	72
13.4 Disqualification .....	73
13.5 Errors in Loading or Announcing.....	75
13.6 Examples of errors in Loading.....	76

## 1. IPC POWERLIFTING REGULATIONS

### 1.1 IPC Powerlifting recognized competitions

IPC Powerlifting Recognized Competitions include:

- IPC Competitions (Paralympic Games, IPC Powerlifting World Championships, IPC Powerlifting Regional Championships)
- IPC Sanctioned Competitions (World Cup)
- IPC Powerlifting Approved Competitions (National, Invitational, International Powerlifting competitions endorsed by an NPC).

The designation of competition table is available in Appendix 1.

### 1.2 Competition Cycle

A 4-year-cycle for Championships will be adopted as follows:

- Year 1: Regional Championships (the competition cycle for Regional Championships may be adjusted where they are included within Regional Games)
- Year 2: World Championships
- Year 3: Regional Championships (the competition cycle for Regional Championships may be adjusted where they are included within Regional Games)
- Year 4: Paralympic Games

### 1.3 Competition Management

The programme of events which is approved by IPC PO shall not be modified by the Local Organizing Committee (LOC) without prior agreement by IPC PO and or the appointed Technical Delegate (TD).

Only IPC Powerlifting and or the appointed Technical Delegate is authorized to grant exceptions on the programme (e.g. in case of high or low numbers per event, restricted entries on competitions, etc).



IPC Powerlifting alone shall have the right to manage World Championships and sanctioned competitions. The words World and IPC Powerlifting may not be used in connection with any Powerlifting event without the consent of IPC Powerlifting.

IPC Powerlifting is empowered to formulate all rules and regulations for the conduct of such competitions. All regulations set by IPC Powerlifting for the above mentioned competitions must be announced and published six months prior to the first day of the competition.

IPC Powerlifting shall have jurisdiction over all matters not assigned by the rules to the referees, or other officials and shall have power to postpone events and give directions consistent with rules adopted for conducting any event.

For IPC Competitions the entry criteria (number of athletes/NPC, MQS, list of events, etc.) shall be defined in the Qualification Documentation and will be published on the IPC Powerlifting website ([www.paralympic.org/Powerlifting](http://www.paralympic.org/Powerlifting)).

For World/Regional Championships and World Cups IPC Powerlifting may allow Organizing Committees to limit the number of competitors per country per event.

At all IPC Powerlifting recognized International competitions (except Paralympic Games) each country is allowed to enter a maximum of 10 senior male and 10 senior female competitors spread throughout the range of the 10 male and female bodyweight categories. There must not be more than 2 senior competitors from any one country in any particular bodyweight category.

At all IPC Powerlifting recognized International competitions (except Paralympic Games), each country is allowed to enter a further maximum of 10 junior male and 10 junior female competitors spread throughout the range of the 10 male and female bodyweight categories for juniors. There must not be more than 2 junior competitors from any one country in any particular bodyweight category.

Where there are up to ten (10) lifters in a single bodyweight category there can be one group of lifters. Wherever there are more than ten (10) lifters competing in the same bodyweight category then sub groups should be formed with a maximum of ten (10) lifters per sub group.





Where sub groups are formed they should be as equal in number as possible and the order of grouping shall be determined by the starting weight declared at weigh-in. The lifters with the lowest starting weights will form the first group to lift, with progressively higher starting weights forming subsequent groups as necessary.

#### **1.4 Paralympic Games**

For Paralympic Games all relevant information is included in the Paralympic Games section of the IPC website ([www.paralympic.org](http://www.paralympic.org)).

## 1.5 AH Formula

In such cases where numbers of entries per specific category are less than three, bodyweight categories will be combined as agreed upon by the LOC and IPC Powerlifting and then the AH formula applied to determine athletes competition ranking and medals (Appendix 2).

At National competitions approved by IPC Powerlifting where entry numbers are low in specific categories (2 or less per category) then combined groups should be formed to consist of 3 or more lifters per group and the AH formula will apply.

Where overall total number of lifters is low then combined groups should be formed for each gender.

At International competitions approved by IPC Powerlifting specifically where entry for a competition is stated as a restricted and or combined “open” competition (e.g. Regional Games) and the AH formula is automatically applied the following combined groups should be formed and medals will be awarded for each group:

Where there are 15 men and or 15 women, or less, in total, then the subsequent bodyweight and gender groups should be formed creating 2 equally divided medal events, except where other formal agreements have been made between IPC Powerlifting and competition organisers:

Examples..

Men: up to 72.00kg inclusive and

Men: from 72.01kg & Over

Women: up to 61.00kg inclusive and

Women: from 61.01kg & Over

Where numbers of entries and declared bodyweights do not naturally allow for using the exact example offered above, then the two (2) medal event groups should always be as equally divided as possible.

Where there are 16 men and or 16 women, or more, in total then the subsequent bodyweight and gender groups should be formed creating 3 equally divided medal events, except where other formal agreements have been made between IPC Powerlifting and competition organisers:

Examples..

Men: up to 65.00kg inclusive

Men: from 65.01kg up to 88.00kg inclusive

Men: from 88.01kg and Over

Women: up to 55.00kg inclusive

Women: from 55.01kg up to 73.00kg inclusive

Women: from 73.01kg and over

Where numbers of entries and declared bodyweights do not naturally allow for using the exact example offered above, then the three (3) medal event groups should always be as equally divided as possible.

## **1.6 Athletes' Eligibility**

All competitors must adhere to the IPC Nationality Policy: IPC Handbook – Section 2 - Chapter 3.1 - IPC Athlete Nationality.

At IPC Competitions, and sanctioned competitions all competitors shall be licensed by IPC Powerlifting in accordance with the IPC Athlete Licensing Policies.

From a classification perspective the provisions of the Classification Manual apply. For more specific details refer to the IPC Powerlifting classification rules and regulations.

<http://www.paralympic.org/Powerlifting/RulesandRegulations/Classification>

## **1.7 Minimum Qualification Standards (MQS)**

An MQS is set to promote a higher standard of competition.

IPC Powerlifting will define the MQS for IPC level Competitions and Regional Games and publish these in the Qualification Guide for the respective competition.

The Minimum Qualifying Standards will be constantly reviewed and can be adjusted, up or down, for specific competitions (even mid World or Paralympic quadrennial cycle).

The review and any adjustment will be done where proven to be in the best interest and advancement of the sport.

Any adjustment to an MQS will not then be brought into force until after the next major event following any such adjustment made.

Detailed table on Appendix 3

## 2. IPC POWERLIFTING TECHNICAL OFFICIALS

### 2.1 Uniform and Dress Code

All IPC Powerlifting officials, including classifiers must always be appropriately dressed in clean and tidy uniform when on competition duty in the following attire:

#### Male Officials

Men must wear the most up to date official IPC Powerlifting approved suit with the relevant IPC Powerlifting referees or classifier badge sported on left breast pocket, with a white shirt, IPC Powerlifting official tie and black shoes.

#### Female Officials

Women must wear the most up to date official IPC Powerlifting approved suit with the relevant IPC Powerlifting referees or classifiers badge sported on the left breast pocket; the suit can consist of an official jacket and skirt or trousers with a white blouse, IPC Powerlifting official scarf & black shoes.

### 2.2 Technical Officials Selection, Roles and Responsibilities

Every IPC Powerlifting recognized competition is required to have a minimum number of appointed IPC Powerlifting qualified technical officials and classifiers in attendance.

IPC Powerlifting will maintain a compiled list of currently licensed referees and classifiers from which any final selection of officials will be made.

Each and every official has to renew their license every four years according to the IPC Powerlifting License renewal process.

To ensure continued developmental and experiential opportunities for as many IPC Powerlifting licensed officials as possible/practical, a rotational system of selection will be used. This will be at the total discretion of IPC Powerlifting.

For selection of the International Technical Officials (ITOs) the following criteria will be taken into consideration:

- The integrity of the competition
- An individual's recent experience and overall competence across all aspects of IPC Powerlifting officiating,
- The Region where the competition takes place
- The respective cost to an LOC.

All officials appointed by IPC Powerlifting must always conduct themselves in line with the IPC Code of Ethics.

Licensed officials that have any other role and or any involvement with a competing NPC (e.g. Coach, Team Manager, Official Delegate or athlete) will not / must not be selected for any officiating duty during the entire course of an IPC Powerlifting recognized competition, unless in such a circumstance that there is a totally free day where their NPC has no competitors in any of a specific days session (e.g. entire morning and afternoon sessions) and the appointed technical delegate in conjunction with the LOC, agree that there is a mutual benefit and valid opportunity for the individual to gain more experience for advancement / promotion of the individual.

However, where agreed to in such circumstance all associated costs for any travel (home to home), accommodation, meals and wherever applicable per diem, will be NOT provided/covered by the Organizing Committee as the individual and or their NPC are responsible to cover such cost.

At IPC Powerlifting recognized competitions the officials that will be selected and appointed are as follows:

### IPC level Competitions

For all IPC level Competitions, IPC Powerlifting will appoint the necessary number of classifiers, a Technical Delegate, and a minimum of twenty one (21) IPC Powerlifting certified technical officials from outside the host country. IPC Powerlifting will also appoint a Technical Delegate Assistant for Paralympic Games and World Championships and also for other International events, , if deemed necessary. IPC Powerlifting will give consideration to appropriately qualified IPC Powerlifting referees from the Host country. At IPC level major events there shall always be a minimum number of officials to adequately cover two full sessions of officials and the majority, if not all, shall be Category 1 to uphold the necessary integrity of the competitions.

Where available a minimum of 8 additional IPC Powerlifting qualified officials from within the organizing country will also be appointed through full consultation and agreement of IPC Powerlifting.

Where a country hosting a competition does not have the required additional number of active IPC Powerlifting International Officials available alternative arrangements will be made by IPC Powerlifting to ensure there are an adequate number of officials in attendance to cover two full sessions. In such instances the host nation will also be encouraged to hold IPC Powerlifting training courses to develop new officials

At IPC level Competitions, only IPC Powerlifting Category 1 and Category 2 referees shall adjudicate. The Technical Delegate, Assistant Technical Delegate and members of the Jury must all be IPC Category 1 referees.

### IPC Powerlifting Approved level competitions

- Invitational Competitions (maximum 6 countries including the host country)

For an Invitational competition approved by IPC Powerlifting there must be appointed 1 Technical Delegate and 5 internationally certified IPC Powerlifting Officials. IPC Powerlifting will give consideration to appropriately qualified IPC Powerlifting referees from the Host country whilst fulfilling the rules will remain the paramount factor in selecting officials.

- International Competitions (more than 6 countries)

For an International competition approved by IPC Powerlifting there must be appointed 1 Technical Delegate and a minimum of 15 internationally certified IPC Powerlifting Officials. IPC Powerlifting will give consideration to appropriately qualified IPC Powerlifting referees from the Host country whilst fulfilling the rules will remain the paramount factor in selecting officials.

- National Competitions

For a National Competition approved by IPC Powerlifting there must be 1 Technical Delegate and at least 5 licensed IPC Powerlifting referees.

In all IPC Powerlifting approved international / invitational competitions, two referees of the same nationality must not be selected to adjudicate in the same category in a contest of two or more countries.

For officials appointed by IPC Powerlifting, travel costs (home to home), accommodation, meal expenses and wherever applicable, agreed per diem, will be provided/covered by the Organizing Committee. This will be as per any final agreements made between IPC Powerlifting and the LOC and must not be done directly by the individual officials. Arrangements with the appointed individuals (e.g. flights, etc) can be made after notification of their official appointment and as agreed with IPC Powerlifting.

To offer increased opportunities for more officials: Officials who are duly licensed and wish to gain more experience and are willing to fully cover their own costs can put their name forward in writing to IPC Powerlifting for further consideration for duties at any specific event other than the Paralympic Games. Such additional places are not guaranteed but will be considered through negotiation between IPC Powerlifting and the LOC.

For appointment of classifiers refer to the IPC Powerlifting Classification Rules and Regulations section

<http://www.paralympic.org/Powerlifting/RulesandRegulations/Classification>

## 2.3 The Technical Delegate

The minimum criteria required to be considered as an IPC Powerlifting Technical Delegate (TD) is as follows:

- a) A TD must be an IPC PO Category 1 international referee with a minimum of five years qualification / experience on or around the competition field of play and must also have very good verbal and written comprehension of the English language and good knowledge and high level of computer / IT skills.
- b) Must be able to demonstrate an ability to offer good leadership in order to be able to oversee and run competitions effectively and should have other necessary key skills and supporting qualifications (e.g. provide refresher course to the technical officials, training, mentoring and coach education), and undertaking any other training considered necessary by Local Organizing Committees for their officials and volunteers;
- c) Must also be readily available for, and able to fully commit to, and maintain, long working hours prior to and during the competition for which they are appointed.

## 2.4 Technical Delegate duties:

### Prior to competition

- To be readily available to visit the intended host of any given competition for technical general inspection (accommodation, competition venue, training venue, I.T. equipment, results programming, transportation, accessibility etc).
- Keep regular contact with the L.O.C. and especially with the designated Competition Manager.
- Construct and where necessary adapt the competition schedule in agreement with the LOC
- Prepare and where necessary adapt the training session schedules.
- Prepare the daily schedules for the referees and jury.
- To ensure the competition attempt cards are prepared
- Where requested by the LOC to conduct a refresher seminar for national referees in a period of time not less than six months prior to the competition.
- Ensure that Anti-doping provisions are in place and in accordance with the IPC Anti-doping Code and the International Anti-doping Standards and work in close cooperation with the respective IPC department.



### At the competition

- To conduct a technical meeting at least one day before the start of the competition.
- To be present at the competition venue daily from prior to the start of weigh-in until the final medal ceremony or presentation of the day
- To consistently and constantly monitor and oversee the competition in liaison with the LOC Competition Manager and ATD where appointed.
- Ensure the IPC Powerlifting Rules are consistently followed and applied throughout the entire competition.
- Work in liaison with the LOC Competition Manager to ensure a well presented medal ceremony takes place.
- Hold meetings with the referees / jury members as considered necessary to offer and receive feedback regarding the competition or other matters. Where scheduled this should be after each session / day of competition.
- To oversee the results in liaison with the LOC Competition Manager.
- To forward the official results to the IPC Powerlifting office upon conclusion of the competition.
- Ensure that Anti-doping provisions are in place and in accordance with the IPC Anti-doping Code and the International Anti-doping Standards and work in close cooperation with the respective IPC department.

## 2.5 The Jury

At Paralympic Games, World and Regional Championships or Regional Games or other international major events a Jury will be appointed to preside over each lifting session. The five (5) persons Jury will consist of only IPC Powerlifting Category 1 referees each of whom must be from different member nations. All members must have very good verbal and written skills and full comprehension of the English language.

A reserve jury member must always be designated for each Jury session and must also be an IPC Powerlifting Cat 1 referee.

For the Paralympic Games, World and Regional Championships the appointed Technical Delegate shall assign the Jury for each session of the competition.

## 2.6 The President of the Jury

The role of the President of the Jury is as follows:

- Before each competition, the President of the Jury must satisfy himself/herself that all other members of the Jury have a complete understanding of their role.
- To ensure that the IPC Powerlifting technical rules are appropriately and consistently applied throughout the competition.
- To replace adjudicating Category 2 referees for Category 1 referees in case of a record attempt; the Jury can be utilised for this in such cases.
- To take any necessary remedial actions following consultation with the other jury members.
- To compare and to verify the manual and the computer results are consistent & correspond.
- To record the accurate results in the athletes IPC Powerlifting Athlete record book and then ensure the Athlete record book is distributed back directly to the athlete or his coach.

## 2.7 Members of the Jury

The function of the Jury is to support the TD in ensuring that the technical rules are appropriately and consistently applied throughout the competition.

All members of the Jury must do an evaluation of each and every lift in each session. This can be done by a system of lights similar to the referees (where available) and or otherwise must be manually recorded on the score sheets provided.

Designated members of the Jury are also responsible for carrying out the kit check prior to the weigh-in (ref point 4.5 - Kit Check); during the competition the jury will be seated together near the field of play in such a position to ensure a totally unimpeded view of the competition.

During the competition the Jury may, by a majority decision, replace any referee whose decisions in its opinion prove them to be incompetent. The referee concerned must have received a verbal warning prior to any action of dismissal.

If any member of the Jury wishes to query or challenge a referee's decision and has a majority consensus of the other members of the Jury, all queries and challenges must be presented through the President of the Jury to the respective referee. Where available the Jury can use a system of lights for calling a referee to the Jury table to address such queries'. The President of the Jury must consult with the other members of the Jury and take the appropriate remedial action based upon a majority verdict.

If a serious error occurs in the refereeing which is contrary to the technical rules, the Jury may take appropriate action to correct the mistake. This must be via the president of the Jury in all circumstances. Where the decision is unanimous the Jury may at their discretion grant the lifter a further attempt.

The Jury can never change the collective decision of the three referees except in the case that an official protest against the referees' decision is lodged according to the Protest conduct procedures. (See point 5.2 Appeals and Protests pg 37)

## **2.8 Referees**

Three IPC Powerlifting referees adjudicate an IPC Powerlifting competition. They are the Chief Referee (also known as the Head Referee) and two side referees.

The three adjudicating referees must always seat themselves in what they consider to be the best viewing positions around but not directly on, or too close to, the platform or where they are restricting the view of the members of the jury.

Referees can be given a range of duties throughout the duration of the competition (e.g. being a Chief Referee in one category does not preclude a referee from being given a side referee or other officiating duty in another category where timing is sufficient).

IPC Powerlifting shall retain their own unique identity with no alignment to any other similar organisation, or their rules, therefore all officials used at approved competitions should have relevant IPC Powerlifting qualification.

At national level referees can be non-English speaking as long as there are others in attendance that can speak English.

At Regional level referees must have at least a basic understanding of the English language, both oral and written; IPC PO reserve the right to exercise an option for less fluent speaking candidates to take an exam in their native language to qualify as a Regional level referee and not be considered for any further advancement to International level.

Further information about all levels of IPC Powerlifting referees and the qualifications required can be found in the IPC PO Referees Qualification and Development Pathway at <http://www.paralympic.org/Powerlifting/Athletes/Officials>

## 2.9 The Chief Referee

The Chief Referee will always be seated behind the head of the competitor to more easily observe the necessary rules are not being broken e.g width of the athletes grip etc, and will always be facing towards the audience. The Chief referee is also responsible for the following:

- Everything taking place on the field of play complies with the IPC Powerlifting rules.
- Checking the bar is correctly loaded, horizontal and centred in the racks
- The heights of both racks (supports) are at the required height requested by the announcer
- Giving an audible command and visual signal to the official speaker / announcer when the bar is correctly loaded and aligned and the racks are at the required height
- Consulting with the two side referees, the Jury and or any other official as considered necessary in order to more efficiently expedite the competition.
- Giving the necessary commands and signals to the lifter for each attempt made throughout their session as described in points 13.4 “Start Command” and “Rack Command”.

## 2.10 Referees Duties

### ***Before the competition***

All three referees must jointly ascertain that:

- a) The platform and competition equipment comply in all respects with the rules.
- b) The Competition Bars and Discs are checked for weight discrepancies and all defective equipment is discarded.

- c) The scales work correctly and are accurate – check official certification where appropriate
- d) The lifters weigh in within the limits of weight and time for their bodyweight category.
- e) The lifter's costume and personal equipment comply with the rules in all respects.

**During the competition**

All three referees must also always check during competition that:

- a) All IPC Powerlifting rules are applied to and complied with by the lifter and the coach
- b) The bar is correctly loaded at the weight requested by the announcer. The referees can be offered a weight chart for this purpose
- c) The lifter's costume and personal equipment are exactly as declared, examined and recorded at the kit check/weigh-in (the same applies following a successful record attempt).
- d) If either of the side referees has reason to doubt a lifter's integrity in respect to the point above, they must, after the completion of the lift, inform the Chief Referee of any suspicions.
- e) All three referees must then re-examine the lifter's costume and or personal equipment. If the athlete is considered guilty of wearing anything that is not according to the rules and or was not checked and recorded at the weigh-in he must be disqualified immediately
- f) Ensure that only the lifter moves the barbell to a new position on the stands. This can be with or without the requested assistance of the spotter / loaders. The coach is never allowed to touch the bar but can request the bar is moved by the spotter loaders.
- g) In such cases, the timekeeper shall not stop the clock. It is the coach or lifters responsibility to ask for this assistance.

- h) The starting position of a lifter is according to the IPC Powerlifting rules.
- i) If either of the side referees considers the starting position of a lifter is incorrect prior to the chief referees' command for the start of a lift, he/she must immediately raise a hand to draw attention to the fact that there is a potential fault. This **must not be done** once the command 'start' has been given
- j) If attention is drawn to a potential fault prior to the start command and there is then a majority consensus among the three adjudicating referees that a fault exists, the Chief Referee will not give the command "start". The lifter or his coach must, upon verbal request to the jury, be informed of the reason for his / her not receiving a start command. The President of the Jury will be responsible for conveying such information to the lifter.
- k) The lifter will then only have the remainder of any unexpired time allowance in which to correct his/her starting position and receive the chief referees' command 'Start'.
- l) Referees and all other officials must refrain from giving any advice, comments or feedback during the competition and must never receive any verbal and or written information concerning the overall progress of the competition. Any official considered to be offering coaching advice during competition that could affect the outcome of the competition will first be warned orally and then relieved of duty if deemed necessary.
- m) Referees must never attempt to influence the decisions of the other referees.

#### On conclusion of each session of the competition

The three referees on duty must sign all the necessary official protocols and any other documents requiring a signature (e.g. record applications, results sheets, etc)

### **2.11 Competition Secretary**

Where one is appointed, the competition secretary is primarily responsible for accurately recording the progress of the competition; other duties of the competition secretary are as follows:

- a) To verify the lists of competitors in terms of entered weight, body weight, IPC Powerlifting ID number, etc
- b) To supervise the drawing of lots before the weigh-in.
- c) To record the bodyweight if deemed necessary during the weigh-in.
- d) To issue passes to the lifters and the relevant two (2) maximum team officials for admittance to the warm-up room.
- e) To supervise with the Marshall the order of lifting during the competition.
- f) To supervise the registration of any new records set during the competition.
- g) Ensure that all relevant officials' check and sign the official score sheet, record certificates and any other document requiring signatures

## **2.12 The Local Organizing Committee Technical Officials**

Under the direction and guidance of, and through full consultation with, IPC Powerlifting the local organising committee (LOC) will appoint the following officials who must all be qualified IPC Powerlifting referees with relevant experience for the level of competition: To ensure the standing and integrity of the competition is not compromised, IPC Powerlifting has the final say on all officials appointed or used.

### **Speaker/Announcer**

The speaker/announcer also acts as a Master of Ceremonies for the actual competition and is primarily responsible for assisting with the efficient running order of the competition whilst keeping everyone duly informed. The speaker announcer must refer to the IPC PO order of competition guideline offered in appendix 4 and follow the set procedure to ensure fully consistent and standardised practice. The relevant competition information announced by the speaker/announcer should also be displayed upon some form of electronic notice board erected in a prominent position.

He/she will announce due notice of any weight change deadlines.

He/she is responsible for clearly announcing to the Chief Referee and the chief spotter the weight (always in kilograms) and the rack height setting required for the next attempt, along with the name of the lifter who is next to compete and also informing the following lifter due to the platform they need to be readily prepared.

When the bar is loaded to the announced weight, the rack height has been adjusted and the platform cleared for lifting, the Chief Referee will indicate this fact verbally and visually by raising his/her arm in the direction of the speaker/announcer who will immediately and clearly announce in the following given order:

- a) "The bar is loaded",
- b) "To .....kgs"
- c) "For the (1st, 2nd, 3rd) attempt"
- d) "From ..... (country name)"
- e) Call the lifter by his/her full name to make sure he/she is aware and ready to proceed to the platform at which precise moment the timekeeper must also start the attempt clock running for the appropriate amount of time.

### **Time Keeper**

The time keeper is responsible for accurately recording the time a lifter is allocated for starting his/her next attempt after being duly called to the platform by the announcer.

The competitor has two (2) minutes to start the lift following the completion of the announcers call unless a lifter is following himself (e.g. fourth, record attempt), when he will receive three (3) minutes instead of two (2) minutes to make his next attempt.

The timekeeper must start the clock only after the athletes' full name is announced, at the end of the speakers' announcement sequence, and give an audible signal to make the lifter aware of one minute remaining. The timekeeper must stop and reset the clock as soon as the 'start' command and signals are given by the chief referee.



The timekeeper is also responsible for manually operating/recording all other time allowances as required with a separate timepiece, such as a countdown timer if necessary, (e.g. after an attempt, the lifter must leave the platform within 30 seconds after he/she has left the bench, and the lifters next attempt must be relayed to the competition secretary via the Marshall, having been noted down and signed for by the coach and countersigned by the Marshall before 1 full minute has elapsed starting from the time the lifter leaves the bench)

Once the timekeeper has started the clock for an attempt being made, it must only be stopped when:

- a) The chief referee gives the command and signal 'Start'
- b) The allocated time allowance has elapsed
- c) The Chief Referee, at his/her discretion, gives a direct verbal command to 'stop the clock' for any valid reasons.

If the lifter does not start his attempt within the given time allowance, the timekeeper must call "time" and the Chief Referee shall give the audible command "rack". The lift will be declared a 'no lift' and the attempt will be forfeited. The start of the bench press is to coincide with the commencement signal of the Chief Referee.

## **Marshall**

The Marshall responsibilities are as follows:

- a) To function as the manual card controller and assist in the efficient running order of the competition.
- b) To accept, check and verify all the new and changed attempts registered by the lifters or their coaches.
- c) To arrange the attempts given by the lifters or their coaches in an orderly fashion, dictated first by weight and, where necessary, when a given weight requested is the same, then by lowest lot draw number and always in this order.

- d) Present appropriately ordered attempt cards to the speaker/announcer, one by one, either manually via the competition secretary or directly via a computer screen.
- e) Only the Marshall can accept a new or changed attempt.
- f) Every change must be written down directly on the attempt card only by the lifter or his coach in black or blue ink after which it will then be countersigned by the Marshall in red ink only, allowing one minute from the time of the lifter leaving the bench after his previous attempt to informing the competition secretary, via the Marshall, of the weight required for his next attempt.

## Technical Controllers

The Technical controllers (minimum of 2) have the following responsibilities:

- a) The Chief Technical controller has to attend the Kit Check
- b) Assist in controlling official access into the warm up room and access onto the Field of Play (FOP).
- c) Ensuring only athletes for the specific event (bodyweight and gender) and designated coaches (as per the specific rules for the competition) are allowed in the warm up room or in / near the entrance of the warm up room.
- d) Helping to maintain and assisting with the efficient running order of the competition, presentations, and medal ceremonies.
- e) Ensuring athletes are audibly informed and ready on timely manner for any presentation of the athletes, competition and for medal ceremonies.
- f) Ensuring athletes and their coaches are audibly informed of their last chance to change the 1st attempt five (5) minutes prior to the start of their particular event.
- g) Visually monitoring the athletes and confirming that the athletes are wearing only approved lifting costume and other such personal equipment as checked against the official list before they are allowed to enter onto the platform.

- h) Making sure the athlete and their coach do not enter onto the field of play until the timekeeper has started the countdown clock

## 2.13 Spotters/Loaders

- General

Spotter / Loaders play a major role in IPC Powerlifting and should have:

- a) a sound knowledge and understanding of the IPC PO rules, a reasonable level of comprehension of the English language, a general competence and viable background of working with free weights and around athletes with a disability
- b) fully understand the differences between guiding, passing and adequately spotting a bar for lifters across a wide variety of disabilities
- c) A coaching qualification and or fitness qualification incorporating the use of free weights as recognised by the National federation and/or IPC PO is preferred; a proven track record of working with IPC PO athletes on the international stage would be further advantageous; previous experience of working with free weights is essential
- d) Where requested to do so individuals identified as spotter / loaders must make themselves readily available for any training deemed necessary by IPC Powerlifting, including attending an IPC Powerlifting rules orientation workshop at least three days prior to any competition; all associated costs for any training identified will be the responsibility of the organising committee

IPC Powerlifting will maintain the unequivocal right to have the ultimate and final say on the use of any individual identified as a potential Spotter Loader at all IPC Powerlifting recognized competitions.

Where an individual is offered such a position but then found during training or competition to be incompetent at the designated role, they will be removed and replaced with immediate effect. As this is related to the athletes' health and safety an initial warning will not necessarily be given.

There must never be less than three (3) or more than five (5) spotter loaders on the FOP at any one time and the group will consist of one Chief spotter and a minimum of two (2) and a maximum of four (4) assistants (side spotter / loaders); there should be a least two individuals identified as having the ability to perform the Chief spotters role. At major events 5 spotter loaders for each and every session is preferred.

The spotters combined roles are:

- to assist the Chief referee in the smooth, efficient and orderly running of the competition and
- keeping the equipment and platform, clean, tidy and safe.

Spotter / Loaders must never offer athletes any coaching advice or guidance at any time. Any spotter / loader breaking this rule can be immediately removed from the FOP, without previous warning being necessary.

All spotter loaders must be consistently dressed with competition t-shirt or polo top, wearing clean and tidy clothing at all times with no advertising on any clothing.

- Chief Spotter/Loader

The individual identified as the Chief spotter has to follow the direction and guidance of the Chief referee yet is solely responsible for:

- a) Giving general guidance and direction to his side spotters to ensure the bar is correctly and efficiently loaded and unloaded
- b) Ensuring that the racks are set at the height announced by the speaker and that the bar is placed horizontally and centrally in the uprights prior to every lift he is attending before audibly declaring to the chief referee that the 'bar is loaded'
- c) Making sure that the bar, bench and platform is kept clean and tidy and at the request of the Chief Referee and to generally ensure that the platform is well maintained, presenting a neat and tidy appearance at all times.

- d) Can also assist the lifter to reposition or realign the bar or lift the bar out of the racks yet he must only do so following a direct request from the lifter or his coach under their guidance and following any commands or directions given by them.
- e) He/she must never touch the bar during the attempt unless directed to do so by the chief referee or following the command to 'rack'
- f) The lift out should be a positive and firm lift out and over across the chest line of the lifter (always following any guidance offered by the lifter). Once the lifter gives any positive indication of having control of the bar it should be released in a positive but very controlled manner into the extended arms of the lifter and the Chief Spotter should stand back and away to the side as quickly as possible so that the chief referee can see and command the lifter to 'start'.
  - Side Spotter/Loaders:

Must always be in attendance and alert to the side of the bar during every attempt with both hands interlocked together and no more than 10cm underneath, but never touching, the end of the bar (sleeves or collars) until commanded to do so.

Must follow the movement of the bar (shadowing the move) down and back up again being in total readiness to relieve the lifter of bar in case it goes out of control or where they are requested to take the bar by the lifter or following the command from the chief referee to 'rack'. This same command could be given when the Chief Referee deems the lift to have been attempted but unsuccessful e.g. the bar moving downwards during the press phase.

Side spotters/loaders can:

Assist the lifter to take the bar out of the racks at the beginning of the lift, but only if requested by the lifter or his coach.

Assist in replacing the bar after the attempt but only following the command from the chief referee to 'rack'.

The side spotter/loaders must never touch the bar or the lifter during the actual attempt, e.g. during the period of time that elapses between the commands 'start' and 'rack'. If the lifter is

deprived of an otherwise successful attempt by the error of a side spotter/loader and through no direct fault of the lifter, he/she may be awarded another attempt at the discretion of the referees but this additional attempt will take place at the end of the round.

Assist the lifter or his coach with the bench strapping. The spotter loaders must never do this alone instead of the coach or athlete.

### **3. THE COACH**

The coach plays a pivotal role for the athlete especially where the athletes' welfare, health and safety is concerned. As such the National body of any coach entering the warm up room or the field of play of any IPC Powerlifting recognized competition has the full responsibility to ensure that their coach has a formal coaching qualification that is acknowledged by his National body and/or IPC Powerlifting and available proof of appropriate and valid insurance cover for coaching. The coach should also have a sound knowledge and understanding of the most up to date and current IPC Powerlifting rules.

The coach is allowed in the warm up room to assist his/her competitor in getting prepared for competition and must always wear any official ID/accreditation as given out by the LOC at all times and openly show the ID/accreditation whenever asked to do so by IPC Powerlifting officials.

There will never be more than two accredited members of coaching staff per team in a warm up room at any one time.

The coach is allowed to assist the athlete getting to and or leaving the platform and onto/off of the bench as required.

It is the responsibility of the lifter or his coach to check that the rack height is at the given and officially recorded height prior to being called to the platform because once the bar is announced as being ready and the name is called by the speaker, the clock will be started and any further requested adjustments to the upright supports will be made within the lifter's two-minute allowance.

The coach can assist the athlete with strapping, either doing this by themselves, or with assistance of the side spotters or side referees

Once on the competition platform, the coach must never touch the bar, the racks or the lifters arms and hands during the lifters preparation period; he can offer verbal instruction to the lifter or to the spotter loaders in order for them to assist the lifter in their final preparation

During the lift coaches must remain within the designated coaching area as marked out, or as directed by the Jury and or Technical Controller in charge.

If a coach wishes to challenge a decision they must take the protest to the President of the Jury and make an official protest on the relevant form and pay €100 within 1 minute. They must never enter communication with any of the referees.

A coach should always conduct themselves in a professional manner in keeping with representing their country and the sport of IPC Powerlifting in general, especially whilst on the field of play.

The Coach must always wear appropriate clean, tidy plain clothing and footwear, which must never have any form of advertising or sponsors logo's except that of the lifters Nation and or any other IPC / IPC PO pre approved National kit. Hats of any kind should never be worn on the F.O.P

Any coach deemed as bringing the sport into disrepute in a malicious manner and or for reasons of gaining unfair advantage will be made to leave the competition venue and will have their accreditation revoked.

## 4. PRE-COMPETITION PROCESSES

### 4.1 Entries

A lifters nominated bodyweight category must be stated on the Final Entry Form 6 weeks prior to the competition.

Lifters must meet the published Minimum Qualifying Standard (MQS) for their body weight category (where relevant).

However each competing nation is allowed to enter a maximum of one (1) lifter who has not met the minimum qualifying standard, in either and or both the men's or women's competition, where that nation has less than three (3) lifters competing in either or both of the men's or women's competition.

The nominated bodyweight category is considered final; however, except in the case of the Paralympic Games where bodyweights given on the final nomination form remain absolute, each lifter will have the option of changing categories, up or down one (1) bodyweight category only from the category nominated on the final entry form but this can only be done once (1 time) and it must be during the Technical Meeting. A penalty fee of €100 (Euro) will be imposed for any change. There will be no other opportunity for a change of bodyweight categories and instead the athlete will be disqualified, withdrawn from the competition and recorded in the results as DNS (did not start).

## 4.2 Technical Meeting

For all IPC Powerlifting recognized competitions a technical meeting will be held at least one day prior to the start of the actual competition to allow a technical briefing to take place with the NPC official representatives (a maximum of two representatives per NPC are allowed and it is mandatory one of them to have a good knowledge and understanding of English and of the rules). Where space is considered too limited IPC Powerlifting will retain the right to reduce this number to one representative per NPC.

During the briefing the following matters will be addressed:

- a) Roll Call by country
- b) Confirmation of participation/changes athletes' bodyweight categories
- c) The Competition Schedule
- d) Protocols and any other relevant matters

Any adjustments that might need to be made to the competition schedule will be effected following the Technical meeting and all NPCs will be accordingly informed of any changes in a timely manner.



### **4.3 Technical Officials Meeting**

Once the technical meeting with the NPCs is over a meeting of the competition technical officials will take place directly afterwards.

### **4.4 Lot Draw**

The drawing of lots is a process where lifters are allocated a number by which they will be weighed-in, and compete during the competition where lifters have chosen the same weights for their next attempts. They will lift in the numerical order of the draw.

The draw can be done randomly by computer at IPC Competitions level, during or at the end of the NPCs Technical Meeting.

In all other IPC Powerlifting competition levels (e.g. Sanctioned or Approved) the draw can be manually done by any two from three of the following officials: the TD, the Competition Secretary and/or the President of the Jury.

‘Lots’ can be drawn any time prior to the start of the weigh-in to establish the order of the weigh-in and lifting but the time and process chosen has to be through agreement with the Technical Delegate and Competition Secretary.

### **4.5 Kit Check**

The ‘Kit check’ will usually be carried out 15 minutes prior to the start of the weigh-in. However it is at the discretion of the TD, Competition Secretary and appointed officials for the session, it can be agreed to commence at an earlier pre determined time prior to the weigh-in for the category or session that they will compete in but only if all lifters for the particular category or session are duly informed and available.

All lifters kit checks must be carried out at the designated time. There will be no checking of kit carried out during weigh-in. Athletes arriving outside the designated kit check time will still have to be seen by the officials tasked with carrying out kit check (if time allows) and will have to pay a fine of €100.

A minimum of three appointed Technical Officials (usually Jury members) and the Technical Controller will be responsible for the full kit inspection, measuring of all personal clothing and equipment and checking it off against the list on the kit inspection form.

All lifters must have their IPC Powerlifting ID card, IPC Powerlifting athlete's record book, lifting uniform and other personal competition equipment checked at the kit check. Any athlete not presenting their IPC Powerlifting ID card and IPC Powerlifting athlete's record book at the kit check will be subject to a fine of €100.

All of the athletes' kit and personal equipment must be clean, tidy and considered fit for purpose or it must be refused by the officials.

Athletes should present all of the following to the Technical Officials at kit check:

- IPC Powerlifting ID card
- IPC Powerlifting athlete's record book
- Lifting Suit
- T-Shirt
- Shoes
- Bra – always to be presented on the kit check table. It should never be checked whilst on the athlete
- Head–dress (females)
- Bench Straps
- Belt
- Bandages
- Wrist straps
- Plasters

For more details on the description of the above mentioned equipment refer to section 12.10.

#### 4.6 Weigh-In

The weigh-in of the competitors must commence no earlier than **two hours** before the start of the competition for any given category or session.

The maximum duration of the weigh-in period will be **one and a half hours**.

All lifters in the category or session must attend the weigh-in, which must be carried out in the presence of the three referees appointed for the particular category in which the lifter will compete, except where an exception is necessary for gender reasons.

Lifters must always be weighed in the pre-drawn numerical order of lifting (Lot draw).

Where a lifter is not ready when called in due turn, they will be moved to the end of the weigh-in list for their category.

The weigh-in of each competitor will be carried out in a private room with only the competitor, his/her coach or manager and the three appointed referees present. The Competition Secretary can be in attendance to assist with recording data with the agreement of the TD in order to expedite the process and efficiency of the weigh-in and competition.

The IPC Powerlifting ID card and IPC Powerlifting athlete's record book must be presented at the weigh-in. Any athlete not presenting their IPC Powerlifting ID card and IPC Powerlifting athlete's record book to the referees table at the time of entering the weigh-in room will be liable for an instant fine of €100.

Lifters can choose to be weighed nude or in minimal underwear, no other clothing is allowed and always without any Prosthesis or Orthosis.

Where female competitors are being weighed the usual procedure can be tailored to ensure that the lifters are weighed by officials of their own gender.

At the further discretion of the Technical Delegate additional female officials or other female assistants may be utilised purely for this purpose.

Each lifter may only be weighed once. Only those lifters whose bodyweight is heavier or lighter than the limits of the category initially entered are allowed to return to the scales. They must return to the scales and make weight within the limit of the one and a half hours allocated for the weigh-in otherwise they will be eliminated from the competition. Lifters trying to make weight can only be re-weighed after all other lifters in the same bodyweight category have been called to the scales but they can be re-weighed as often as remaining time and orderly progression by lot draw number allows.

A lifter may only be weighed outside the time limit of one and a half hours if he is readily available within the usual time limit but due to the number of lifters trying to make weight he is denied the opportunity of being re-weighed. In such a case he/she will only be granted just one attempt to re-weigh but this is purely at the discretion of the referees whose decision is final.

During the weigh-in, the lifter or his coach must declare in confidence a starting weight and the height of the upright supports of the bench (rack height). All of these details must be clearly entered on the official attempt card, witnessed and signed by the lifter or his/her coach and retained by the official conducting the weigh-in to be passed on to the Marshall who then retains and manages the cards throughout the respective competition session. The lifter or his coach will not be given any additional attempt cards for use during the competition.

The lifters agreed bodyweight and their 1st attempt must always be taken and recorded in confidence and must never be made public until all the lifters competing in the particular category or session have been weighed-in.

#### **4.7 Athletes Presentation**

There should be a presentation of the lifters prior to each session (individual or combined categories).

Following direction from the Technical Controller lifters will be lined up in the order as given on the competition session start list and they will then be presented in an orderly fashion in front of the audience. (ref., also point 2.1.2)

This must take place whenever possible no less than 15 minutes before the designated starting time of the competition session, to ensure it does not cause unnecessary interference with a lifters' warm up and also allows for all lifters to continue final preparation well before the call for final changes to the first attempt is made.

As soon as a lifters name is announced during the presentation the lifter will be directed by the Technical Controller to leave the presentation line up and return to the warm up room to continue their preparation, except where any different presentation protocol is agreed with the LOC i.e Major events – Paralympics etc.

## 5. PROTEST (GENERAL CONDUCT, PROTESTS & APPEALS)

In general the IPC Code of Ethics applies (available on the IPC website [www.paralympic.org](http://www.paralympic.org) on Handbook section).

Additionally in IPC Powerlifting the following conditions also apply:

### 5.1 Conduct

In all cases, where in the opinion of IPC Powerlifting, any gross or blatant misconduct has taken place, or where the sport has been blatantly brought into disrepute by lifters, coaches, technical officials or any other national team officials, representatives or delegates, IPC Powerlifting reserve the right to institute the procedures set out in IPC Handbook for breaches of the IPC Code of Ethics.

Any lifter, coach or other team official who by reason of their misconduct on, near or around the competition platform or stage/arena is considered likely to bring the sport or competition into disrepute, will be officially warned.

If the misconduct continues, the President of the Jury, Technical Delegate, or the Chief Referee in the absence of a Jury or Technical Delegate, will disqualify the lifter and direct him, along with the coach and or official, if deemed necessary, to leave the venue.

The Team Manager or Head of Delegation must then be officially informed of both the warning and the disqualification.

The President of the Jury or Chief Referee can also, following consultation with other members of the jury or referees, immediately disqualify a lifter, coach or any team official without serving an official warning if they are of the considered and agreed opinion that any misconduct is serious enough to warrant such immediate disqualification. The Team Manager or head of delegation must be informed of the disqualification immediately, or where this is impractical at the earliest and most convenient opportunity.

## 5.2 Protests and Appeals

Protests can only ever be made at International approved events / competitions where an appointed Jury is in attendance (see also point 2.5) and at no other event will protests be accepted.

In all IPC Powerlifting recognized competitions, any protest against referee's decisions, complaints regarding the progress of the competition or against the behaviour of any person or persons taking part in the competition must be made only to the Jury.

All protests to the Jury must be made in writing on an official IPC Powerlifting protest form (see appendix 4) and be presented to the President of the Jury, accompanied by the cash sum of €100 within one minute of the action against which the protest is being made. Any protest must be made by the Team Manager or Coach in their absence, never by the lifter.

Where an official protest against the referees decision (of no lift) is lodged, in full accordance with the Protest conduct procedures, then the President of the Jury will immediately check with all other members of the Jury regarding their own independent judgement and decision made, which must have been done by either a system of lights (where available) and or on manually recorded, official score sheets. (ref., point 2.7)

Where (under these very strict guidelines) it is unanimously agreed that the referees' decision is considered incorrect a "good lift" will be given.

Where it is not immediately & unanimously agreed amongst members of the jury that the referees' decision is incorrect then the original decision offered will stand and the protest will be dismissed / declined with no further right to protest or appeal allowed.

If the Jury in its final deliberation consider that the protest is of a malevolent nature, the entire sum of the protest fee will then be retained and will be considered as having been donated to IPC Powerlifting.

If deemed necessary, the Jury may temporarily suspend the progress of the competition (see note below) and even retire to a private quarter to consider its verdict. After due deliberation, and upon reaching a verdict, the President of the Jury will inform the complainant about the

outcome in writing on the same protest form where it will clearly identify the protest as being upheld or declined.

The Jury's decision is final in regard to any protests made and there will be no further discussion entered into and or further right of appeal to IPC PO or any other body.

**Note:**

Where the jury decide to temporarily suspend the competition, upon its recommencement the next lifter to compete will be given three minutes in which to commence his / her lifting.

## **6. RESULTS**

### **6.1 Individual Competitors**

The result of a lifter will be calculated on the best competition lift performed.

Where there are less than three athletes per category then the AH formula will be applied (see point 1.5).

All results must be formally recorded on the results sheet, checked and signed off by all the referees on duty.

### **6.2 Teams**

The winner of the Team trophy will be the country with the highest number of points amassed during the competition.

The points will be awarded as follows but only the points of the six best-placed lifters of each country must ever count towards the teams overall score-at all competitions.

First place	12 points
Second place	11 points
Third place	10 points
Fourth place	9 points
Fifth place	8 points
Sixth place	6 points
Seventh place	4 points
Eighth place	3 points
Ninth place	2 points
Tenth place	1 point

### 6.3 Tie Breaking for Team Points

In the event of a tie in the overall scores of two countries, the nation having the largest number of first places will be ranked first.

In the event of a tie between two nations having the same number of first places, the one having the most second places will be ranked first and so on through to the placing of the maximum six scoring lifters.

In the case of a tie with exactly the same first, second, third, etc places the two teams will be equally ranked first and be co-holders of the title. The next team will then be third and so on.

## 7. RANKINGS

IPC Powerlifting shall maintain World and Regional rankings based on the results submitted by the LOCs from IPC Powerlifting recognized competitions.

A ranking system based on the best lift of each athlete will determine the best performing athlete per weight category per season. Where 2 lifters have same total, the lifter with lighter bodyweight will be ranked higher.



For further details on the ranking system and selection criteria for Paralympic Games refer to ([www.paralympic.org](http://www.paralympic.org)).

Only athletes that are licensed for the season in which the performance took place and have an international sport class status “Review” or “Confirmed” will have their results recognized for the official ranking lists.

## 8. RECORDS

### 8.1 General

During regular competition progression the overall weight of the barbell /discs must always be increased in minimum multiples of a full 1kg.

Where a lifter is successful with an attempt the usual progression of his next lift must be at least 1kg. However, during the natural course of a competition a lifter can also make a request for a record attempt that is not a rounded multiple of a full 1kg (I.e. 500gms / .5kgs)

Record attempts can be made on any lift in the natural sequence of increasing weight during the competition or as a fourth attempt at the end of the round but the weight of the barbell must always be increased by the minimum of 500 grams (.5kg) in excess of the existing record otherwise it will be deemed invalid.

If such a record attempt is successful, only the lower closest multiple of a rounded 1kg will be recorded on the score sheet for the purpose of the final result. This should also take into account where a minimum 1kg increase was not carried out for any single attempt (see example below). The exact weight lifted will appear on the record application.

For example if 133.5kg is requested for the lifter’s second attempt and the lift is successful, then 133.5kg must be entered on the competition score sheet and 133.5kg should be entered on the record application. However this would be recorded as 133kg for result and ranking purposes if it remained the best successful attempt.

World Record attempts which are not multiples of a full 1kg can be requested and granted on any, or all, of a lifter's prescribed attempts provided that he maintains a minimum increase of 500 grams. For example if the current record is 100.5kg, then a lifter may take the following attempts:

1st attempt	2nd attempt	3rd attempt	4th attempt
101 kg	101.5 kg	102 kg	102.5 kg

Attempts 1, 2, 3 and 4, if successful, will all be records irrespective of the fact that the weight of the bar was not increased by the minimum 1kgs for competition purposes. In the example above the minimum increase of 1kg for competition purposes for any individual attempt was not requested on any of the four attempts so the whilst the lowest multiple of a rounded 1kgs is actually 102kgs it was in fact only achieved by using an increase of .5kg and not the minimum 1kg therefore 101kgs must be recorded as the competition result; the record will be recorded as 102.5kgs.

## 8.2 World Records

Applications for world records will only be accepted when the existing record has been broken at an IPC Powerlifting recognised / approved competition, in accordance to the rules, and where an appropriate number of appointed IPC Category I referees and Jury are in attendance during the attempt. The record will only become validated where anti-doping testing is carried out on the world record performance and a negative result is returned.

During the World record attempt only IPC Powerlifting referees Category 1 can adjudicate. Category 2 referees must always be replaced with Category 1 referees in cases of world records and members of the attending Jury can be used.

The good faith and competence of referees of all member countries is beyond reproach where records are concerned and so consequently referees of the same nation, and from the same nation as the lifter, can assure a World Record. However, whenever possible, referees from different countries from that of the lifter and of other referees should always be used.

In IPC Powerlifting recognized competitions World records can be accepted without the need for re-weighing the barbell or lifter, as long as all processes of weighing the equipment or lifter had been accordingly followed as per the IPC Powerlifting rules and regulations.



Where the weighing of all the weight discs/barbell/collars used in the competition was not carried out prior to the competition, the three adjudicating referees must weigh the barbell and weights and record their precise weight immediately after the specific session in which a successful World Record has taken place is entirely completed.

Immediately after a lifter is successful in a world record attempt he/she must be inspected by the three adjudicating referees' on the competition platform. If the lifter is found to be wearing any illegal substance or apparel, including clothing not recorded during the official kit check, the lift will immediately be declared invalid and the lifter will also be disqualified from the competition.

When a lifter has succeeded in his third attempt with a lift that falls within 10 kg of a current world record, he/she may at the discretion of the Jury or the Chief Referee in the absence of a Jury, be granted a fourth attempt outside the competition. A 4th attempt may also be granted if the 3rd attempt, already being a world record attempt, was not successful. In no other case can fourth attempts be granted.

As soon as a new record is established any lifter then wishing to attempt a new record must exceed the previous one set by a minimum of 500 grams (.5kgs) otherwise it will be invalid.

Following a successful World record attempt the three adjudicating referees' must always fully complete the respective Record application form (see

Appendix 5) and a copy of the official and signed score sheet must also accompany the record application.

Original copies of the record application form and official results must be sent to the IPC Powerlifting Office.

World records will only be considered for ratification if the IPC Powerlifting Office has received a copy of the written report and record application within the specified time limit of one month and it will then only be fully ratified if IPC/IPC Powerlifting has received the necessary (negative findings) report from the designated anti-doping control body.

Without any exceptions including the Paralympic Games and World Championships, World Records will only be accepted where appropriate drug testing was carried out on the lifter.

Where two lifters break the same record on the same day but in different places the lifter who weighed the lightest during the weigh-in at the two different competitions will be the sole record holder.

When two lifters break the same world record on the same day but in different places, and they weighed exactly the same during the weigh-in at the separate competition they are competing in then the two lifters will be co-holders of the record.

### **8.3 Regional Records**

Regional record applications will only be accepted, recognised and validated when the existing record has been broken at an IPC Powerlifting recognized / approved competition and where an appropriate number of appointed IPC Category I referees and Jury are in attendance during the attempt and random anti-doping testing was readily available; Regional records will still be ratified even though the athlete who sets the record performance may not have been randomly tested at the competition.

## **9. MEDAL AWARDS**

The winner receives the gold medal, the second a silver and the third the bronze medals respectively.

If two lifters register an identical bodyweight at the weigh-in and eventually achieve the same lifting result at the end of the competition, then both will be re-weighed after the end of the session. After re-weighing if they still weigh the same they will then share the placing and each one will receive a medal. For instance if two lifters are in the first place then 2 gold medals must be given and the next lifter must receive the bronze medal.

Where an MQS is applied to a competition and the weight category is not considered viable (e.g. 2 or less) the medals will be given to the second place only if the MQS is met. If the MQS is not achieved then only a diploma will be given.

Where a competition does not have an MQS and an event is not considered viable (e.g. 2 or less) then the minus one rule applies.

Where only one athlete per weight category participates then, where appropriate, and without compromise to other categories, the athlete will be grouped either to the closest (lower) weight category and or with several other categories, in such a case there is more than one category that is not viable and then the AH formula will be applied. Only one set of medals will be given.

Where the AH formula competition format is applied there will be medals awarded for each combined group.

Any junior lifter achieving a high enough total to win a medal in the junior competition and for the open senior competition, then a medal shall be awarded to this athlete for each eligible competition (i.e. Junior & Senior event, with the exception of the Paralympic Games where only one medal will be given).

At World and Regional Championships and or other Games, where it has been pre-agreed with IPC Powerlifting, a team challenge trophy or cup will be awarded.

Team awards will be given for the first three positions only. At World and Regional Championships the winning team will receive and retain a challenge cup for one year.

## **10. PROCESS FOR APPROVED COMPETITIONS**

For most updated and detailed processes and minimum requirements for Approved competitions refer to Appendix 6.

At National competitions approved by IPC Powerlifting all lifters must be from the host country and up to a maximum of three (3) other lifters from any other NPC (3 in total not per NPC) in good standing with IPC can also compete.

For National competitions IPC Powerlifting may consider to approve single gender competitions yet only where it is formally agreed to also run separate competition for the opposite gender as well.

For numbers of Technical Officials required at the various levels of approved competitions refer to Section 2.

## 11. RETURN TO FIELD OF PLAY DECISIONS

At sports venues, it is the responsibility of the team physician to determine whether an injured athlete may continue in or return to the competition. This decision should not be delegated to other professionals or personnel. In the absence of the competent physician, other professionals or personnel should adhere strictly to the instructions that he or she has provided. At all times, the overriding priority should be to safeguard the health and safety of athletes. The outcome of the competition should never influence such decisions.

## 12. IPC POWERLIFTING TECHNICAL RULES

### 12.1 Events and Programme of Events

There are 10 separately defined bodyweight categories for both Male and Female athletes.

#### BODY WEIGHT CATEGORIES - MEN

Up to 49.00kg	up to 49.00kg
Up to 54.00 kg	from 49.01 kg to 54.00 kg
Up to 59.00 kg	from 54.01 kg to 59.00 kg
Up to 65.00 kg	from 59.01 kg to 65.00 kg
Up to 72.00 kg	from 65.01 kg to 72.00 kg
Up to 80.00 kg	from 72.01 kg to 80.00 kg
Up to 88.00 kg	from 80.01 kg to 88.00 kg
Up to 97.00 kg	from 88.01 kg to 97.00 kg
Up to 107.00 kg	from 97.01 kg to 107.00 kg
Over 107.00 kg	from 107.01 kg and over

## BODY WEIGHT CATEGORIES - WOMEN

Up to 41.00 kg	up to 41.00 kg
Up to 45.00 kg	from 41.01 kg to 45.00 kg
Up to 50.00 kg	from 45.01 kg to 50.00kg
Up to 55.00 kg	from 50.01 kg to 55.00 kg
Up to 61.00 kg	from 55.01 kg to 61.00 kg
Up to 67.00 kg	from 61.01 kg to 67.00 kg
Up to 73.00 kg	from 67.01 kg to 73.00 kg
Up to 79.00 kg	from 73.01 kg to 79.00 kg
Up to 86.00 kg	from 79.01 kg to 86.00 kg
Over 86.00 kg	from 86.01 kg and over

Additions to the lifters bodyweight will be made for amputees as follows:

- for each through ankle amputation add:  
1/2kg for all weight categories
- for each below knee amputation add:  
1 kg for up to 67kg bodyweight  
1½kg from 67.01kg bodyweight and over
- for each above knee amputation add:  
1½kg for up to 67 kg bodyweight  
2 kg from 67.01 kg bodyweight and over
- for each complete hip disarticulation add:  
2½ kg for up to 67kg bodyweight  
3kg from 67.01kg bodyweight and over

## 12.2 Competition Format

The IPC Powerlifting recognized competitions can run with the following competition formats:

- 1) In designated single body weight categories for Men and Women

2) With the AH formula (see point 1.5)

The competition format is to be discussed with and approved by IPC Powerlifting.

### 12.3 Age Groups

IPC Powerlifting recognizes two (2) age groups for all its approved / recognized competitions with the exception of the Paralympic Games as these will always have only one combined group per category / event.

**Juniors:** from day of 14 Birthday up to 19 years of age **by the 31<sup>ST</sup> of December of the year of the competition.**

**Seniors:** From 20 years of age **by the 31<sup>ST</sup> of December of the year of the competition.**

**Masters:** It is not compulsory to have a masters category; however, where an LOC wish to hold such an event (either as an integrated or stand-alone competition) the age for this group is to be taken from **40 years of age by the 31<sup>ST</sup> of December of the year of the competition** – if approval is required then the usual application for competition has to be submitted to IPC PO.

From a participation perspective an athlete is now eligible to compete at the various levels of IPC Powerlifting competitions as follows:

- Approved competitions:  
**From Day of 14<sup>th</sup> Birthday**
- Regional Championships or Regional Games:  
**From 15 years of age by the 31<sup>ST</sup> of December of the year of the competition**
- World Championships or Paralympic Games:  
**From 16 years of age by the 1<sup>ST</sup> of January of the year of the competition**



## 12.4 Competition Venue

### Competition Warm up

In order to prepare themselves for their competition, the competitors must be provided with a controlled/marshalled warm-up area located in an accessible area in very close proximity to the competition area and must have adequate accessible toilets nearby.

There will never be more than two accredited members of coaching staff per team in a competition warm up or training room at any one time.

The competition warm up room must have the following equipment:

- a) An appropriate number of approved benches, in accordance with number of competitors and compliant with the IPC Powerlifting rules.
- b) A proportionate number of barbells and sets of weights, collars, bench straps, chalk and chalk boxes, etc. in relation to the number of benches.
- c) An adequate amount of water available in relation to the number of competitors
- d) Loudspeakers linked with the announcer's microphone
- e) A video display linked to the competition scoreboard readily showing the names of the competitors in the order of the competition round system
- f) A parallel display of the timing clock operating on the FOP in the competition area
- g) Video screen(s) showing the activity on the competition platform.

### Training Area

At IPC Competitions level or sanctioned events additional training facilities must be made available.

They can be at the competition venue or at an alternative site but in either case they must be controlled / marshalled and have accessible toilets nearby.

The training room must be equipped with the following:

- a) An appropriate number of IPC PO endorsed / approved benches, relevant to the number of competitors and fully compliant with IPC PO the rules
- b) A relevant number of barbells and sets of weights, collars, bench straps and chalk, etc. in relation to the number of benches and competitors.
- c) An adequate amount of water freely and readily available in relation to the number of competitors using the facility
- d) Calibrated scales in order for athletes to accurately monitor their bodyweight

#### Other facilities required

At all IPC Competitions level or Sanctioned competitions, the following additional facilities must also be provided at the competition venue:

- Athletes' Rest area
- Media centre
- VIP room
- IPC PO Offices
- General weigh-in room (for athletes self monitoring bodyweight)

#### **12.5 Field of Play (FOP)**

In IPC Powerlifting recognized competitions the Powerlifting competition must take place on either a stage (FOP) or any flat level area FOP, which can have an actual platform (as defined below) or just a clearly visible and defined marked out level (platform) area in a non slip contrasting coloured material to the main floor.

A stage should be used in all IPC / IPC Powerlifting major competitions and events (Regional Championships, Regional Games, World Championships and Paralympic Games)

The following requirements must always be complied with:

- Where used an IPC Powerlifting competition platform area should measure 4m x 4m.
- The surface of the platform must be flat, firm, non-slip and level.
- If a stage is used it should never be higher than 700mm, minimum 11m deep x 12m wide, maximum 12m deep x 12m wide.
- Where a stage is used a specific platform is not required. Where a platform is not used a flat and level area of 4m x 4m must be marked out in a contrasting colour.
- Where a platform is used it must never exceed 50mm in height and always have a rounded or bevelled/ramped edge.
- Entry and Exit ramps\* with a non-slip surface must be provided for easy access of wheelchair users and less ambulant athletes; standard size stepped access to the stage must also be provided in addition to the ramps.

*Note:*

\*There should always be two separate ramps for the entry and exit to/from the stage/platform in order to maximize the flow and efficiency of the competition.

## 12.6 Sport Equipment

All equipment used (benches, bars, discs, etc) for any IPC Powerlifting recognized competition has to all be in very good, safe, clean and tidy condition and exactly as per the current IPC Powerlifting rules and specifications at the time of application for recognition of a competition.

Equipment that merely meets the IPC Powerlifting specifications does not mean it is considered “approved” until such a time that it is checked and an official and formal approval is given by IPC Powerlifting.

At IPC Powerlifting Sanctioned and Approved competitions where it is established that equipment to be used has already been checked and had formal IPC Powerlifting approval at a previous major event (e.g. Regional or World Championships, Paralympic Games, etc) the same equipment can be used at future IPC Powerlifting Sanctioned and Approved competitions - if the TD considers it reasonable to do so. In such circumstances the TD may report any defective equipment to IPC Powerlifting with a recommendation that the equipment at the venue (or some parts of it) be subject to a further full approval process.

Powerlifting bars to IPC Powerlifting specifications and approval must always be used in the training and competition arenas of all recognized competitions.

Weightlifting bars must never be used at any IPC Powerlifting recognized competitions for training or competition purposes.

### 12.6.1 IPC Powerlifting Bench & Specifications

The bench must be made of sturdy construction and provide maximum stability and conform to the following dimensions:



Example of bench

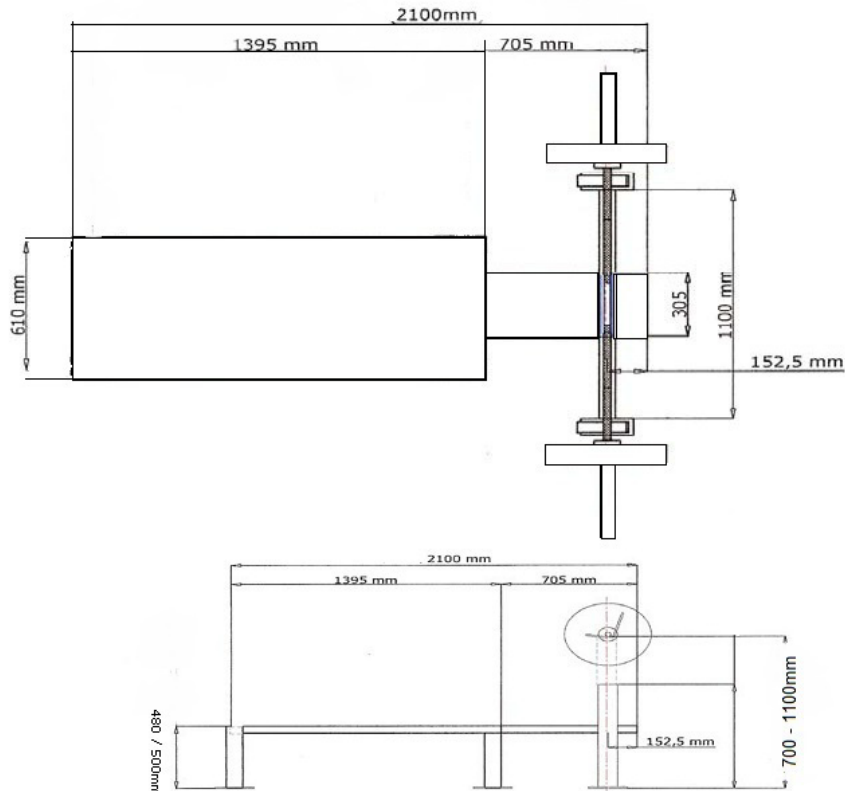

### Length

The upholstered bed of the bench must be flat, level and a total of 2100mm in length.

### Width

The main section of the bed of the bench shall be 610 mm wide, but for a distance of 705 mm from the head end, the width must only be 305 mm leaving two equal shoulders of 152.50 mm.

### Height

The height must never be less than 480 mm and never exceeding 500 mm measured from the floor to the top of the flat surface of the bed of the bench without it being depressed or compacted.

### Stands

The height of the rack uprights on all benches used in an IPC PO approved competition must be adjustable from a minimum 700mm to a maximum of 1100 mm measured from the floor to the bar rest position.

Minimum width between insides of bar rests shall be 1100 mm.

### 12.6.2 Bar, Discs and Collars

The following differential tolerances will apply for all IPC Powerlifting approved Competition Bars, Discs and Collars (components):

Each component weighing more than 5 kgs must not exceed the tolerance parameters of +0.1% to -0.05%. (e.g. a 25kgs disc can only be overweight by a maximum of 25g and underweight by never more than 12.5g)

Each component weighing 5 kgs or less must not exceed the tolerance parameters +0.1% to -0% per component. (e.g. a 5kgs disc can be overweight by + 5 g but must never be underweight)

### 12.6.3 The Bar

In all IPC Powerlifting recognized / approved competitions, or those organized and or conducted under the rules of IPC Powerlifting, only IPC specification Powerlifting bars as supplied by an IPC Powerlifting officially approved preferred supplier/manufacturer must be used.

From 2013 onwards bars should have a green cap at the end of the sleeves to clearly identify they are made to IPC Specifications. Bars approved by IPC Powerlifting since 2008 will remain acceptable. (ref., also point 12.6)

IPC Powerlifting approved competition bars must always be used in competition and in the warm up room.

Approved powerlifting training bars must be used in the training room.

A damaged bar, or a bar in some way determined as unsafe, unfit for purpose and/or unusable by the IPC Powerlifting approved referees on duty should be replaced.

The bar shall be straight and well knurled and grooved and shall conform to the following dimensions:

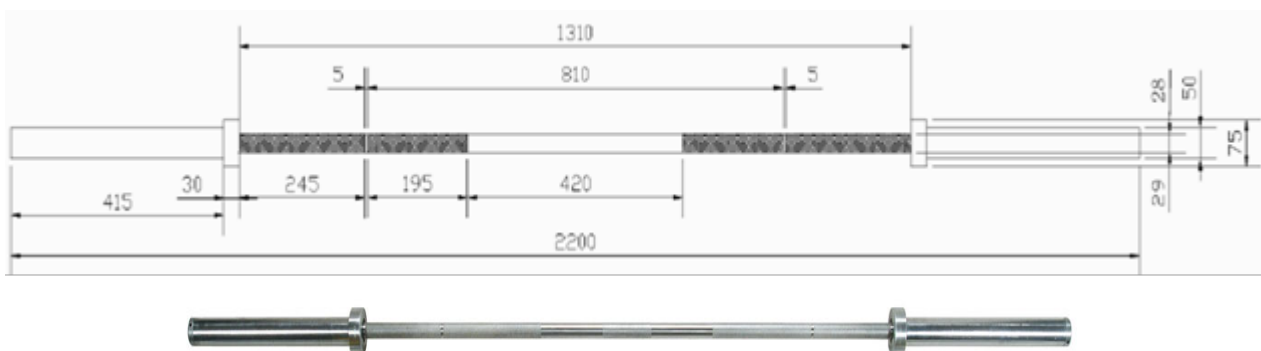

- Total overall length must not exceed 2200 mm.
- Distance between the collar faces is not to be less than 1310mm or greater than 1320 mm
- Diameter of the bar is never to be less than 28 mm (preferred) or greater than 29 mm.
- The combined weight of the bar and collars has to be 25 kg with the collars weighing 2.5kgs each.
- The diameter of the sleeves should be 50 mm

There should be a machined marking to precisely indicate a distance of 810 mm between the internal (facing) edges of the machined marking.

#### 12.6.4 The Discs

In all IPC Powerlifting recognized competitions only weights approved by IPC Powerlifting and supplied by an IPC Powerlifting officially approved and/or licensed supplier/manufacturer can be used.

Approved competition discs must always be used on the competition platform and in the warm up room yet training discs can be used in additional training rooms.

Discs must have IPC Powerlifting approval and must conform to the following:

- a) All discs used in competition must conform to the maximum differential tolerances.
- b) The diameter of the hole in the centre of the disc should not be less than 50.5 mm or greater than 53 mm.
- c) Only the following range of discs will be used in IPC recognized competitions:  
0.5 kgs - 1 kgs – 1.5kgs – 2 kgs - 2.5 kgs – 5 kgs – 10 kgs – 15 kgs – 20 kgs - 25 kgs & 50kgs (50kg discs must be used for all attempts of 260kg and above yet can be used at lower weights at the discretion of the Chief referee in collaboration with the appointed Technical Delegate where considered to be a matter of health and safety for spotter loaders.  
Where 50Kg discs are not available, metal 25kgs discs can be used (in this particular instance only and only in line with rules where 50kgs would have to be used i.e. for 260kg and above)  
Where metal discs are used under such circumstance they must always be of the same manufacturer as other discs and used on the inner most part of the sleeves.
- d) Metal record discs of precisely .250gms must also always be readily available for record purposes.

- e) Discs must conform to the following colour code for instant identification:
- 50 kg = Black
  - 25 kg = Red
  - 20 kg = Blue
  - 15 kg = Yellow
  - 10 kg = Green if rubber discs are used, otherwise any colour if metal and
  - under 10 kgs = any colour.
- f) All discs must be visibly marked with their relevant weight value and always loaded with the heaviest discs innermost on the sleeve, thereafter loaded in descending order of weight with lightest discs towards the outside.
- g) The first disc loaded on the bar must always be loaded face inwards for the weight to be readily identified. All additional discs will be loaded face out.
- h) The diameter of the largest disc will be 450 mm with a differential of  $\pm 1$  mm.
- i) 450mm competition discs must be covered with rubber or plastic with permanent colours on both sides and or colour coded around the whole edge of the circumference of the weight.

#### 12.6.5 The Collars

Top quality collars each weighing 2.5kgs must always be used in competition



Example of type of collar to be used

#### 12.6.6 Scales

There should always be at least two sets of scales available to athletes at major competitions and at other levels of IPC Powerlifting recognized competitions where possible.



One set will be solely for official weigh-in at competition and one at the training site or other convenient location so athletes can self monitor their weight as required and all scales must conform to the following requirements:

- a) Weigh in scales should be electronic platform type for the safe and accurate weigh in of athletes sitting on a chair or directly on the scales measuring no less than 850mm x 850mm and no greater than 1m x 1m, whenever there are athletes who cannot stand without aids.
- b) Scales must have the capacity of accurately weighing up to 200kgs in precise increments of 10gms or less.
- c) Where scales are not an electronic / digital type they must have been calibrated and certified as such, by an official Weights and Measures Organisation or the scales manufacturers, within 3 months of an IPC Powerlifting recognized competition for all record purposes. Such scales used in any IPC Powerlifting recognized competition still have to be checked by the referees for accuracy prior to each event.
- d) Where a scales are an electronic digital type and have an original certification of calibration from the manufacturer they have to be set to zero and checked for accuracy by the IPC powerlifting appointed technical officials prior to the competition and for each and every subsequent competition session or group weigh-in afterwards for record purposes. Where available a print out showing time and date should be done before each session and posted adjacent to the scales for everyone to see calibration has taken place.



Example of electronic digital scales.

The scales can be used with or without a chair.

## 12.7 Scoreboard & Attempt Board

A scoreboard must be set up and displayed in the most practical and visible place on or close to the FOP on which the full order of the competition will be displayed and relayed to, or duplicated in, the warm up room at all major and approved International competitions.

It must show at least the names of the competitors in the order in which they have been drawn before the weigh-in, their country, bodyweight and the result of each lift and final result.

Where an integrated attempt board is used (incorporating lights, timer, name, attempt etc) must be displayed in the most visible and practical place so that everyone can easily follow the run of competition. At major events two boards are preferable yet where only one is provided it should always be placed at the exit side of the F.O.P for the information to be clearly captured on the jury playback video.

## 12.8 Lights



A light system consisting of two rows of three red and three white indicators, which can be either a stand alone system or as part of an integrated attempt board system must be provided by which the referees will make known their decisions following each lift.

The two rows of lights must be arranged horizontally to correspond with the positions of the three referees so that it is easily identified by the competitors, Jury and spectators what decision each referee has made.

Each referee will have a separate control box switch with two switches – one for a white light (good light) and one for a red light (no lift). The Chief referee has a master switch which will also be used for resetting the lights after a decision is made.

The light system must be wired in such a way that all three lights illuminate at the same time and only when the chief referee has pushed his master switch. Lights must never illuminate separately when activated by the referees.

Referees will also be provided with small white and red flags (or paddles) with which to make known their decision in case of an electrical failure of the light system.

Where, by command of the Chief referee, flags or paddles have to be used the referees must always take both flags/paddles in their hands on the Chief Referee's 1<sup>st</sup> command "flags" – the three referees will raise the required flag/ paddle on a 2<sup>nd</sup> signal from the Chief referee to "raise flags".

### **12.9 Timing System**

At all Major IPC Powerlifting Championships and approved International competitions, an electronic timing system must be displayed in a position that is most practical and easily visible (see scoreboard, attempt board and lights sections)

It must automatically give an audible signal for the final one minute and to coincide with this and where there is no buzzer available the announcer must also loudly and clearly call 'one minute' at the precise time.

At other IPC Powerlifting approved competitions where an electronic display is not available a manual clock can be operated by the timekeeper but clear, concise and precise signals must be given in a manner that ensure the coaches and athletes are made fully aware of when only one (1) minute remains.

The timing system will be controlled by a Time Keeper who must be an IPC Powerlifting qualified referee.

### **12.10 Athletes Personal Costume and Equipment**

Lifters must always appear in correct, clean and tidy dress, which must consist of a One-piece lifting suit, T-shirt, Socks, Shoes and Sports Bra.

Any clothing or other personal equipment considered unclean, torn and or unsuitable in any other way will and must be rejected by the referees at the kit check prior to weigh-in.

12.10.1      One piece lifting Suit

- a) The suit can only be made from a one-ply very limited stretch material, e.g. Lycra (maximum 20 %) or cotton-elastane – (maximum 10 % elastane), without any additional patches or padding (it cannot be a weightlifting style suit with any double stitching and or padding)
- b) The lifting costume has to be a one-piece lifting suit with shoulder straps & must never have a zipper fastening.
- c) The straps must be worn over the shoulders at all times while lifting in competition.
- d) The one piece lifting suit can be full length, extending to the ankles and include a stirrup or alternative can be a short leg version. Where a short leg version is used they must never measure shorter than 10 cm along each inseam but must always be well above the knees and as close fitting to the legs as possible. Any other style of lifting costume or uniform will not be accepted.

The lifting suit will also be subject to the following additional requirements:

- e) The lifting suit may bear the badge, emblem, logo and/or inscription of the lifter's nation or national association.
- f) The lifter's name may be placed on any apparel or equipment. Anything which is considered offensive or liable to bring the sport into disrepute is not allowed and will be rejected.
- g) The suit can be of one or more plain colours
- h) No manufacturers or sponsors logo's is allowed to be visible on the lifting suit, unless subject to alternative agreement (e.g. Paralympic Games).

### 12.10.2 T-Shirt

A plain, round neck T-Shirt of any colour, or colours, must be worn under the lifting suit at all times. The T-shirt is subject to the following conditions:

- a) It can be made exclusively of either cotton or polyester, or can also be a mixture of both. No other materials are allowed.
- b) It must be a plain t-shirt or it can be the official T-Shirt of the IPC Powerlifting competition that the lifter is competing at.
- c) It cannot have any pockets, buttons, zippers, collar or a v-neck.
- d) It can have the badge and / or inscription of the lifter's nation, national or regional federation. Any other markings, especially those which are considered offensive or likely to bring the sport into disrepute are not allowed.
- e) It shall not have sleeves, which terminate either below the elbow or up at the deltoid (nor capped sleeves).
- f) Lifters are not allowed to push the sleeves of the T-Shirt up to the deltoid when competing.
- g) It cannot be made of any ribbed material.
- h) It cannot consist of any rubberised or similar stretch material.
- i) It cannot have any reinforced seams.
- j) Is not constructed so as to place seams in a position, which in the opinion of the appointed IPC Powerlifting officials who carry out the kit check, might tend to assist the lifter in Powerlifting competitions.
- k) It must fit loosely enough on the lifter's body to ensure that it does not afford the lifter any physical support.
- l) If there is any doubt a lifter can be asked to put the t-shirt on at the kit check and it can be rejected.

### 12.10.3 Shoes

- a) Shoes must be worn in all cases during IPC Powerlifting competition.
- b) Where there are exceptional circumstances through having a specific disability there has to be a Doctor's certificate placed in the IPC Powerlifting licence/ athlete record book.

#### 12.10.4 Bra

- a) When worn during competition, ladies must only wear a bra without any stiffening, padding or under wiring. A sports Bra is most acceptable.
- b) It must lie totally flat when placed on the kit check table.



- c) The Bra that will be worn during the competition has to be made readily available for checking by the officials at the kit check table and it cannot be requested to have it checked whilst being worn by the athlete during weigh-in.
- d) Any lifter considered to be using the Bra to gain unfair advantage (i.e making too tight to unnaturally raise chest or padding out after kit check) can be challenged from the Jury and Referees which can result in disqualification.

#### 12.10.5 Head dress

- Where a head dress is worn by female athletes it must only be made of a one ply, single, plain coloured material.
- For health and safety reasons a head-dress must never have any sequins or other jewellery attached to it.
- It must always be close fitting to the shape of the head / neckline.
- It must never fully cover the face or go below the neck line where it impedes a referees' view of the neck and shoulders.

#### 12.10.6 Leg/Bench Straps

- a) Any lifter is allowed to have their legs strapped to the bench for additional stability and with the choice of using either one or two straps.
- b) The official competition bench straps (see example below) personal bench straps or a mixture of both can be used.

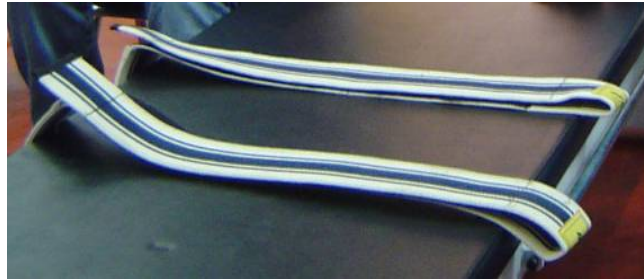

- c) Where any personal bench straps are used, each and every personal strap being used should be presented and shown at the kit check, before weigh-in.
- d) Strapping is allowed anywhere on the legs from the ankles to the top of the thigh but should never be on, across or above the hip line. The only exception to this point being that it should be as low as possible for amputees without hips (also refer to point 12.1). Straps should never be directly across the knee (patella) unless severe contractures of the legs dictate otherwise, in which case it will be at the complete discretion of the classifier on duty.
- e) Strapping of the legs must be done by the lifter himself or the coach; in either case this can be with the assistance spotter / loaders but must always be under the supervision of the referees.
- f) Leg / Bench straps must never be less than 7.5cm, or more than 10cm, in width with no additional padding, metal buckles or loops.
- g) Only Velcro type fastening is allowed.

### 12.10.7 Belt

Competitors may choose to wear a lifting belt.

If worn it must always be on the outside of the lifting suit.

Material and Construction:

- a) The main body shall be made of leather, vinyl or other similar non-stretch material in one or more laminations, which may be glued and/or stitched together but cannot have any

additional padding, bracing or supports of any material either on the surface or concealed within the laminations of the belt.

- b) The belt can have a buckle with one or two prongs or be a 'quick release' type; any type of buckle should be attached at one end of the belt by means of studs and/or stitching.
- c) A tongue loop (maximum 2) shall be attached close to the buckle by means of studs and/or stitching.
- d) The name of the lifter's nation can appear on the outside of the belt but there cannot be any other logos, sponsors or manufacturers markings whatsoever unless due sponsor or licensing fees have been paid.

Dimensions:

1. Maximum width of belt should not exceed 100 mm.
2. Maximum thickness of belt along its main length not to exceed 13 mm.
3. Inside width of buckles maximum 110 mm.
4. Outside width of buckles maximum 130 mm.
5. Tongue loops maximum width 50 mm.
6. Distance between end of belt and far end of tongue loop maximum 150 mm

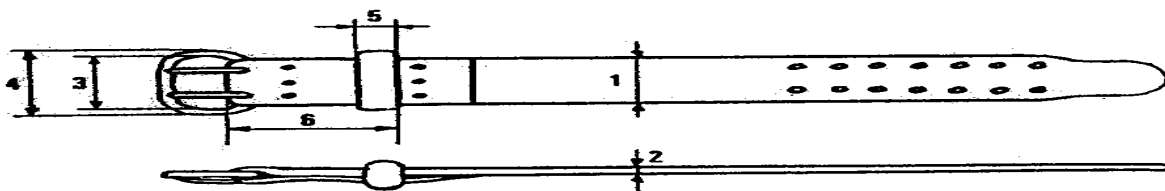

Correct points of measurement

### 12. 10.8 Bandages and Wristbands (wraps)



Example of wrist wraps



Only wraps or bandages of a one ply commercially woven elastic that is covered with polyester, cotton or a combination of both materials or medical crepes are permitted.

Bandages of rubber or rubberised substitutes are strictly forbidden.

Bandages and wristbands must also conform to the following:

- a) Bandages must not exceed 1 metre in length and 80 mm in width
- b) Wristbands not exceeding 100 mm in width may be worn.
- c) A combination of wristband and bandages is not permitted.
- d) If wristbands are the wrap around style, they may have a thumb loop and Velcro patch for securing them. They cannot have any additional type of buckle, loop or other style of fastening.
- e) The thumb loop can only be used for securing the wristband when the athlete is putting it on but the loop must be taken off of the thumb during the actual lift.
- f) A wrist bandage should not extend beyond 100 mm above and 20 mm below the centre of the wrist joint and must never exceed a total covered width of 120 mm.
- g) Bandages over the permitted length or width shall be rejected, but may be cut to correct length and width and resubmitted within the specified inspection time. It is the lifter's responsibility to cut bandages not officials.
- h) Under No circumstances should any IPC Powerlifting officials perform this service.

#### 12.10.10 Plasters

- Plasters must not be worn anywhere on the body without official permission of the Technical Delegate (TD) or, in their absence, the President of the Jury and or the Chief Referee, with the medical officer on duty in attendance, where available.

- Plasters, bandages or band-aids cannot be used as aids to assist the lifter gripping the bar.
- The official competition doctor, paramedic or paramedical personnel on duty may apply plasters to body injuries in a fashion that would not grant the lifter an undue advantage. He/she must consult with the Technical Delegate or in their absence the Head Referee and or President of the Jury.
- At all competitions where a Jury might not be present and there are no medical personnel on duty, the Technical Delegate will have jurisdiction over the use of spot plasters.
- Other types of medical taping / strapping is not allowed

## 13 COMPETITION RULES

### 13.1 The Round System

There are three (3) competitive rounds in an IPC Powerlifting competition.

All lifters must complete each relevant round in sequential order, first by order of the lifting weight chosen and then, where the weight chosen is the same, by the order of the lot draw. The lifter with the lowest lot number drawn for the weigh-in must always lift first.

Only three lifting attempts are ever permitted within the actual competition.

Any additional lifting (4th) attempt for record purposes will be deemed outside the competition and will not be included in the final result for ranking.

The bar must be loaded progressively for each round on the principle of a rising bar whereby each lifter will take his first attempt in the first round, his second attempt in the second round and his third attempt in the third round.

At no other time will the weight of the bar be lowered within a round except for errors due to a incorrectly loaded bar or spotter error as described in the respective section of this book (see points 13.5 & 13.6 Errors in loading) and even then this must only be done at the end of a round.

If unsuccessful with an attempt, the lifter does not follow them self but must wait until the next round before he/she can attempt the same weight again or make a new attempt at a heavier weight.

Having given his/her chosen starting weight at the weigh-in a lifter is then permitted one change of weight for the first attempt.

If he/she is in the first or only group to lift this change can take place at any time up to within five minutes before the start of the first round. Never after the five minute call.

Subsequent groups in the same bodyweight category or session are accorded a similar privilege of weight change but only up until within three attempts from the end of the previous group's last round. The speaker will announce due notice of these weight change deadlines.

The change of weight for the first (1st) attempt can be either higher or lower; however, if a lighter starting weight is requested the overall weight cannot be reduced by more than 7 kg off of the total of the initial weight submitted at the weigh-in. The order of lifting in the first round will be changed accordingly where any weight changes have been made but only where the overall integrity of the competition is not compromised. The appointed Technical Delegate alone has the right to make the final decision on this matter.

Having made his/her first attempt, the lifter or his/her coach must decide upon the weight required for the second attempt. The chosen weight must be filled in where indicated on the official attempt card which will be kept at the Marshalls table.

This must be done before the one-minute time allowance has elapsed (timed from the athlete leaving the bench) and the same procedure is to be followed for the third attempt or subsequent changes.

The weight submitted to the Marshall for second round attempts cannot be changed except where a record attempt is requested and this can only be increased with a maximum of .5kg (500g) except in the following example:

When two (2) lifters nominate 102 kg for a world record attempt and the 1st lifter has been successful and broken the world record, the second lifter is permitted to change his 2nd attempt to 102.50 kg in order to be allowed to attempt to break the new world record with the minimum 500g required.

In the third round attempt, two weight changes are permitted. The weight change can be higher or lower than the previously submitted third attempt. However, these changes are only permitted provided that the lifter has not already been called to the platform by the speaker, or where the bar has already been loaded to his previously submitted weight and attempted by another lifter that he would have otherwise preceded.

## 13.2 The Competition

The competition proper will begin two (2) hours from the actual start time of the weigh-in during which time the warm up and athletes' presentation will take place.

During any IPC Powerlifting recognized competition, only the participating lifter, his/her coach, the adjudicating officials and spotter/loaders will be allowed on or around the competition stage or platform.

Only one (1) national coach or other official member of a lifters staff delegation is ever allowed to be on, or around, the actual field of play at one time; where this is not adhered to a lifter can have their attempt forfeited.

Members of the Jury and other technical officials required for each competition session will be situated in such a position where there is an unobstructed, clear view of the lifter, but (except for the three adjudicating referees) this must always be off of the main platform or stage area (FOP) where one is used.

During the execution of a lift, only the lifter, spotter/loaders and the adjudicating referees are permitted to be present on the stage or around the actual platform. Coaches must always remain within the designated coaching area as marked out or as defined by the Jury or Technical Controller in charge.

From the time the speaker/announcer finishes announcing the athlete's name, the lifter has two (2) minutes to start the lift.

The countdown of the two (2) minutes must only commence immediately following the completion of the full sequence of the speakers announcement explained previously in this rules and regulations book. See point 2.12 Speaker / Announcer

If the lifter is following himself (e.g. an error in loading or a fourth/record attempt) he/she will receive three (3) minutes instead of two (2) minutes to make his/her next attempt.

The lifter or coach must not proceed towards the bench unless directed to do so by the Technical Controller and this must only be when the allotted time has been started following the speakers announcement. Failure to comply with this can result in a lifters attempt being

forfeited or disqualified. Only once directed by the Technical Controller should the lifter make his way onto the field of play.

Once on the bench all lifters must always assume the following starting position, which must then be maintained throughout the entire duration of the bench press once the 'start' command has been given by the chief (head) referee:

The lifters head\*, shoulders (hair or head-dress must not restrict the referees view), buttocks, legs (fully extended – as possible) and both heels must remain on/touching the bench for the entire duration of the lift.

\* The lifters' head must never lift off the bench during the execution of the lift, from when the start signal is given until the lift is completed and arms are at full extension / lock-out.

The lifter must always grip the bar with the thumbs and all fingers being wrapped safely around the circumference of the bar.

The spacing of the lifters hands must never exceed 81 cm, as measured between the forefingers; even where there is a physiological or anatomical challenge creating an imbalance to the lifters grip distance, the inside edge of the forefingers should never be outside of the 81cm markings.

A thumb-less grip is never allowed and will always be considered a 'No Lift'.

If a lifter cannot fully stretch his/her arms resulting from anatomical deformation of his/her elbow he/she must report/identify this fact to the 3 referees and the Jury before getting onto the bench at the beginning of each attempt during the competition.

If a lifter cannot fully stretch his/her legs resulting from anatomical deformation or neurological deficiency he/she must report/identify this fact to the 3 referees and the Jury before getting onto the bench at the beginning of each attempt during the competition.

Special exceptions can be granted for specific disability and medical reasons but these must always have been verified by the IPC PO classifier and recorded in the athletes' licence record

e.g. acute leg contractions not allowing fully extended legs and or both heels to touch the bench.

In addition to the general technical elements previously offered that apply to all lifters, the following additional specific rules also apply for the specific disability groups named below:

#### Les Autres and Spinal Cord Injured Athletes

An Orthosis or special shoes will be allowed for Les Autres and Spinal Cord Injured athletes. These must be formally granted and officially verified by an IPC Powerlifting approved classifier and must always be recorded in the athletes' licence/record book.

#### Cerebral Palsy

Flexed legs can be supported by a wedge which must have been officially verified and granted by an IPC Powerlifting classifier and further checked and approved by the appointed officials at the kit check prior to weigh-in.

Only lifters with Cerebral Palsy can use a special wedge. The use of cushions (wedge) under knees by any other lifters is not allowed in any circumstance.

Overall dimensions of a wedge can be according to the lifter's personal anatomical requirements but the overall width must never exceed 600 mm so as not to overhang the sides of the bench & offer any additional advantage.

#### Amputees

Depending on the type and level of amputation, wherever possible, an athlete's legs, feet and or prosthesis should be extended as fully as possible on the bench.

Special exceptions can be granted for medical reasons but these have to be assessed and verified by an IPC Powerlifting approved classifier and recorded in the athletes' licence/record book.

### **13.3 The Bench Press – sequence of events**

Once led down on the bench the lifter can choose to have assistance from either, the chief spotter, and or side spotters for lifting the bar out of the racks, or can lift the bar out themselves but in all circumstances the coach or the lifter must make the chief spotter fully aware of this when approaching the bench.

Where such assistance is requested by the athlete and or his/her coach, only the official chief spotter and or side spotter loaders are ever allowed to help the lifter to remove the bar from the racks. The ‘assisted’ lift off must be to arms length only and not down to the chest.

After taking control of the bar at arms’ length, the lifter must wait with elbows locked until the Chief Referee’s gives the ‘Start’ command and signal.

#### **13.3.1 The “Start” Command**

An audible command ‘Start’ must be given immediately, as soon as the Chief Referee considers the lifter has firm control of the bar, at arms’ length and with elbows locked (subject to any special medical conditions-refer to IPC Powerlifting Classification Rules and Regulations).

At the same time as giving the loud and clear audible command, the Chief Referee must also give a visual signal which is the downward movement of the outstretched arm.

#### **13.3.2 The “Lift”**

After receiving the start command the lifter must, when readily composed, lower the bar to the chest in a fully controlled manner and without heaving or bouncing the bar visibly stop\* on the chest and then press it upwards again.

\*There must be a noticeable definitive break between the eccentric and concentric (down and up) movement when the bar touches the chest.

After the bar touches the chest, the bar must not sink into the chest in such a way that it is considered to have assisted the lifter or made the lift easier in any way.



The bar must progress upwards in a consistent equal manner to result in an equal extension 'lock out of both arms' to arms length. At no time must there be any staggered movement of the arms during the upward press phase (known as 'walking' the bar).

The bar can stop during the press phase (concentric/upward movement of the bar) but it must never move down towards the chest again during the press phase.

Once the lifter's arms are locked out and the bar is held firmly under control an audible command "rack" together with a backward movement of his/her outstretched arm will be given by the chief referee after which the lifter can replace the bar back in the racks with or without assistance from the chief spotter/side spotters.

### 13.3.3 The "Rack" Command

An audible command 'Rack' must be given when the Chief Referee considers that the athlete has completed the lift and has the bar under control, at arms' length and with elbows locked, or when it is duly considered that the attempt being made is unsuccessful.

At the same time as the audible command the chief referee must also give a visual signal consisting of a backward movement of the outstretched arm

Only once the bar has been replaced in the racks, can the referees announce their joint decision by means of the lights or flags when required.

WHITE LIGHT / FLAG: for a "Good lift"

RED LIGHT / FLAG: for a "No lift"

Upon completion of their attempt, a lifter must leave the FOP stage/platform within 30 seconds after he/she has left the bench. Blatant failure to comply with this can result in disqualification of an attempt.

The lifter or the coach has one minute after the lifter leaves the bench to record the next attempt on the official attempt card which will be in the possession of the appointed Marshall who must countersign to verify the next attempt offered.

The coach must sign the attempt card in blue or black ink and the marshall must countersign each time in red ink.

Where the lifter or coach does not offer their next attempt to the Marshall within the allotted one minute the following conditions must be automatically applied by the Marshall;

If the lifter's attempt was recorded as unsuccessful, the weight on the bar for the next attempt will be recorded at exactly the same weight as the previous attempt.

If the previous attempt was recorded as successful, the weight on the bar for the next attempt will be increased by a further 1kgs only.

Where the change of attempt has not been made within the one minute allowed and the automatic condition is applied and the lifter's next attempt is going to be the second (2nd) attempt then under no circumstances will any further change be allowed, without any right for protest or appeal.

Where the automatic condition is applied and the lifter's next attempt is going to be the third (3rd) attempt then subsequent changes are permissible but only in line with the relevant IPC Powerlifting rules (e.g. two additional changes can be made).

### **13.4 Disqualification**

In addition to failing to comply with any of the general requirements contained in the previous sections, referees must always register a 'NO LIFT' for the lifter for any one or more of the following technical reasons:

- a) Failing to observe the Chief referee's signals (e.g. commencing the lift or replacing the bar back into the racks prior to the Chief Referee's respective commands of 'Start' or 'Rack')
- b) Any change in the elected lifting position during the lifting sequence, between receiving the 'Start' and the 'Rack' commands (e.g. the head, shoulders, buttocks or feet must not raise from their original points of contact with the bench during the bench press sequence)
- c) Any lateral movement of the hands along the bar during the entire lifting sequence.
- d) Any heaving or bouncing of the bar into, or off of, the chest
- e) Any blatant sinking of the bar into the chest where it is apparent that the lifter has gained advantage; i.e. using momentum after the bar has touched the chest to make the lift easier

f) Any downward movement of the bar during the upward press phase (e.g. the bar can stop during the press phase but must not move back down again)

g) Any unequal movement of the arms during the press phase, also known as 'walking the bar'

h) Any uneven extension of both arms during the final 'lock out' stage.

Note:

Whilst the lifter's arms must extend equally, at the same time / rate / speed and the elbows should lock out together simultaneously, the bar does not have to be completely horizontal during the press or on lock out.

i) Any unfinished attempt with any apparent effort; i.e. Failure to 'press' the bar to full extension of the arms at the completion of the lift.

Note: This means that the arms have to positively lock out at the end of the press phase and does not mean that the bar has to return to any given starting point as natural compression has to be considered and this is not a reason for a 'NO LIFT' to be given.

j) Where any contact is made with the bar by any of the spotter/loaders between the Chief Referee's commands / signals of 'Start' and 'Rack'.

k) For any deliberate, or out of control, contact between the bar and the bench upright supports (racks) during the lift in order to make the press easier.

Note:

If the bar hits the racks in an uncontrolled manner during the execution of the lift and is deemed to have assisted the lifter in any way to complete the lift then a 'no lift' will be recorded by the referees.

If the bar has hit the racks during the execution of the lift and the lifter is deemed to have gained no advantage at all then a 'good lift' will be recorded by the referees.

l) Elapsed time - 'Timed Out'

m) In case of World record if the lifter is found to be wearing any illegal substance or apparel, including clothing not recorded during the official kit check.

### **13.5 Errors in Loading or Announcing**

If during any round an attempt is unsuccessful due to an incorrectly loaded bar, spotter error or equipment failure, the lifter will automatically be granted a further attempt by the Chief Referee, at the correct weight.

This further attempt will be at the end of the round in which the error occurred.

If the fault is an incorrectly loaded bar and the attempt has not actually started, then the lifter will be given the option of either continuing at that time or taking the attempt again at the end of the round.

In all other cases, the lifter shall take his/her extra attempt at the end of the round.

If the lifter also happens to be the last lifter in the round the error is made then he will be granted three minutes to start his new attempt.

If the speaker/announcer makes a mistake by announcing a weight lighter or heavier than that requested by the lifter, the Chief Referee will apply the same rules as for errors in loading in making his/her decision.

If for any reasons it is not possible for the lifter or his coach to remain in the vicinity of the platform in order to follow the progress of the competition and the lifter misses his/her attempt because the speaker omitted to announce him/her at the appropriate time or weight, then the weight will be reduced as necessary and the lifter allowed to take his/her attempt, but only at the end of the round.

The Chief Referee will be solely responsible for any decisions taken in the case of loading errors or incorrect announcements by the speaker/announcer.

Any decision made will be given to the speaker/announcer who will then in turn make the appropriate announcement.

### 13.6 Examples of errors in Loading

a) If the bar is incorrectly loaded to a lighter weight than originally requested and the attempt is successful, the lifter may accept the successful attempt and have the lower weight recorded or elect to take the attempt again at the originally requested weight. If the attempt is not successful, the lifter will be granted a further attempt at the originally requested weight. In either case, further attempts may only be taken at the end of the round in which the error occurred.

b) If the bar is incorrectly loaded to a heavier weight than originally requested and the attempt is successful, the lifter will be granted the attempt and will have the higher weight recorded. However, in this one instance only, the weight will be reduced again if required for other lifters. If the attempt is not successful, the lifter will be granted a further attempt at the originally requested weight at the end of the round in which the error occurred.

c) If the weights loaded are not equal on each end of the bar, or any change occurs to the bar or discs during the execution of the lift and despite these factors the lift is successful, the lifter may accept the attempt and have the actual weight lifted recorded or he can elect to take the attempt again. If the attempt is unsuccessful, the lifter will automatically be granted a further attempt. Further attempts may only be taken at the end of the round in which the error occurred.





**Paralympic.org**

**International Paralympic Committee**

Adenauerallee 212-214  
53113 Bonn, Germany

Tel. +49 228 2097-200  
Fax +49 228 2097-209

**info@paralympic.org**  
**www.paralympic.org**

© 2012 International Paralympic Committee – ALL RIGHTS RESERVED  
Photo ©: Getty Images